

RCA No. 619	Original	Sheet No. i	
	Canceling	Sheet No.	
Alaska Fiber Star, LLC.			
TABLE of CONTENTS			
<u>Subject</u>			<u>Sheet</u>
Title Page			Title
Table of Contents			i
Preliminary Statement			viii
Anchorage Service Area Map			ix
Anchorage Service Area Description			xii
Explanation of Symbols			xv
Part I – Definition of Terms			1.1
Part II – General Rules and Regulations			
A. Applicability of Regulations			2.1
B. Applicability of Tariff Rates			2.1
C. Undertaking of the Company			2.2
1. Use			2.2
2. Resale			2.3
3. Identification of Employees			2.3
4. Engineering, Installation, and Maintenance			2.4
5. Through Transmission of Signals			2.6
6. Monitoring and Reporting			2.6
7. Performance Standards and Transmission Specifications			2.6
D. Limitation of Liability			2.7
Tariff Advice No. 11-619		Effective: September 18, 2009	

Issued By: Alaska Fiber Star, LLC.

By: 
 Lisa Phillips

Title: Manager, Regulatory Affairs

RCA No. 619	Original	Sheet No. ii	
	Canceling	Sheet No.	
Alaska Fiber Star, LLC.			
TABLE of CONTENTS			
<u>Subject</u>		<u>Sheet</u>	
Part II – General Rules and Regulations (cont.)			
E.	Other Provisions and Limitations	2.8	
1.	Indemnification	2.8	
2.	Acts or Omissions	2.11	
3.	Limitation on Warranty	2.11	
4.	Defacement or Damage to Premises	2.12	
5.	Intellectual Property	2.12	
6.	Force Majeure	2.12	
F.	Obligation of the Customer	2.13	
1.	Application for Initial Service	2.13	
2.	Service Order	2.14	
3.	Maintenance and Repairs	2.14	
4.	Ownership and Use of the Equipment	2.14	
5.	Fraudulent and/or Illegal Use Prohibited	2.15	
6.	Reimbursement for Damages Required	2.16	
7.	Payment of Attorney's Fees	2.16	
8.	Compliance with FCC Rules Required	2.16	
9.	Power Supply	2.16	
10.	Right of Access	2.17	
11.	Customer Complaints	2.17	
Tariff Advice No. 11-619		Effective: September 18, 2009	

Issued By: Alaska Fiber Star, LLC.

By: 
 Lisa Phillips

Title: Manager, Regulatory Affairs

RCA No. 619	Original	Sheet No. iii	
	Canceling	Sheet No.	
Alaska Fiber Star, LLC.			
TABLE of CONTENTS			
<u>Subject</u>		<u>Sheet</u>	
Part II – General Rules and Regulations (cont.)			
G.	Payments and Charges	2.19	
1.	General	2.19	
2.	Payments of Charges	2.19	
3.	Disputed Bills	2.21	
4.	Notice of Discontinuance	2.22	
5.	Deposits	2.24	
6.	Credit for Service Interruptions	2.25	
7.	Service Interruption Measurement	2.26	
H.	Termination or Denial of Service by Company	2.27	
I.	Customer Owner and Maintained Equipment	2.28	
1.	Obligations of the Company	2.28	
2.	Obligations of the Customer	2.29	
3.	Violation of Tariff	2.30	
4.	Company Liability	2.31	
J.	Special Services	2.32	
1.	General	2.32	
2.	When Applicable	2.32	
K.	Special Pricing Arrangements	2.33	
Tariff Advice No. 11-619		Effective: September 18, 2009	

Issued By: Alaska Fiber Star, LLC.

By: 
 Lisa Phillips

Title: Manager, Regulatory Affairs

RCA No. 619	Original	Sheet No. iv	
	Canceling	Sheet No.	
Alaska Fiber Star, LLC.			
TABLE of CONTENTS			
<u>Subject</u>		<u>Sheet</u>	
Part II – General Rules and Regulations (cont.)			
L.	Special Construction	2.34	
1.	General	2.34	
2.	Jointly Placed Facilities	2.34	
3.	Basis for Cost Computation	2.35	
M.	Inspection, Testing, and Adjustments	2.36	
N.	Confidential Information	2.37	
O.	Assignment and Binding Effect	2.38	
Part III – Special Access Services			
A.	General	3.1	
B.	Channel Types	3.2	
C.	Service Descriptions	3.3	
D.	Service Configurations	3.4	
1.	Two-Point Service	3.4	
2.	Multipoint Service	3.5	
E.	Special Facilities Routing	3.7	
F.	Design Layout Support	3.7	
Tariff Advice No. 11-619		Effective: September 18, 2009	

Issued By: Alaska Fiber Star, LLC.

By: 
 Lisa Phillips

Title: Manager, Regulatory Affairs

RCA No. 619	Original	Sheet No. v	
	Canceling	Sheet No.	
Alaska Fiber Star, LLC.			
TABLE of CONTENTS			
<u>Subject</u>		<u>Sheet</u>	
Part III – Special Access Services (cont.)			
G.	Rate Regulations		3.8
1.	Rate Types		3.8
2.	Monthly Rate Categories		3.8
	a. Channel Termination		3.9
	b. Channel Mileage		3.10
	c. Optional Features and Functions		3.12
3.	Nonrecurring Rate Categories		3.13
	a. Installation of Service		3.13
	b. Installation of Optional Features and Functions		3.13
4.	Mileage Determination		3.14
H.	High Capacity Channel Service		3.15
1.	Basic Channel Description		3.15
2.	Technical Specifications Packages and Network Channel Interfaces		3.15
3.	Optional Features and Functions		3.16
	a. Automatic Protection Switching		3.16
	b. DSL Access Service Connection		3.16
I.	Continuous Property Service		3.17
J.	Individual Case Basis Filings		3.17
Tariff Advice No. 11-619		Effective: September 18, 2009	

Issued By: Alaska Fiber Star, LLC.

By: 
 Lisa Phillips

Title: Manager, Regulatory Affairs

RCA No. 619	Original	Sheet No. vi	
	Canceling	Sheet No.	
Alaska Fiber Star, LLC.			
TABLE of CONTENTS			
<u>Subject</u>		<u>Sheet</u>	
Part IV – Frame Relay Service			
A.	General		4.1
B.	Service Elements		4.2
	1. Frame Relay Data Link		4.2
	2. Frame Relay Port		4.2
	3. Frame Relay PVC		4.2
C.	Regulations		4.3
D.	Rate Regulations		4.7
Part V – Other Data Services			
A.	Virtual LAN Service – High Speed		5.1
	1. General		5.1
	2. Service Elements		5.2
	3. General Regulations		5.2
	4. Rate Regulations		5.3
	5. Planned Service Interruption		5.4
Tariff Advice No. 11-619		Effective: September 18, 2009	

Issued By: Alaska Fiber Star, LLC.

By: 
 Lisa Phillips

Title: Manager, Regulatory Affairs

RCA No. 619	Original	Sheet No. vii	
	Canceling	Sheet No.	
Alaska Fiber Star, LLC.			
TABLE of CONTENTS			
<u>Subject</u>		<u>Sheet</u>	
Part VI – Rates and Charges			
A.	Nonrecurring Charges Applicable to All Services	6.1	
B.	High Capacity Service	6.1	
	1. Channel Termination	6.1	
	2. Channel Mileage	6.1	
	3. Term Discounts	6.2	
	4. Optional Features and Functions	6.2	
C.	Frame Relay Service	6.3	
	1. Data Links	6.3	
	2. Port Connection per Port	6.3	
	3. PVC Based on CIR Speed	6.3	
	4. PVC Rearrangement Charge	6.3	
D.	Virtual LAN Service – High Speed	6.4	
	1. Ethernet Data Links	6.4	
	2. Connection Bandwidth	6.4	
E.	Continuous Property Service	6.5	
F.	Miscellaneous Rates and Charges	6.6	
Tariff Advice No. 11-619		Effective: September 18, 2009	

Issued By: Alaska Fiber Star, LLC.

By: 
 Lisa Phillips

Title: Manager, Regulatory Affairs

RCA No. 619	Original	Sheet No. viii	
	Canceling	Sheet No.	
Alaska Fiber Star, LLC.			
PRELIMINARY STATEMENT			
<p>This Tariff is submitted to provide a standardized schedule of Alaska Fiber Star, LLC's (AFS) rules, regulations, rates, and services.</p> <p>Chapter 42.05 of the Alaska Public Utilities Commission Act, Sections 3 AAC 48.200 through 3 AAC 48.420 of the Alaska Administrative Code, and rules, regulations, and orders of the Regulatory Commission of Alaska now in effect or hereinafter issued, are hereby incorporated by reference as a part of this Tariff.</p>			
Tariff Advice No. 11-619		Effective: September 18, 2009	

Issued By: Alaska Fiber Star, LLC.

By: 
 Lisa Phillips

Title: Manager, Regulatory Affairs

RCA No. 619

Original

Sheet No. ix

Canceling

Sheet No.

Alaska Fiber Star, LLC.

ANCHORAGE SERVICE AREA MAP

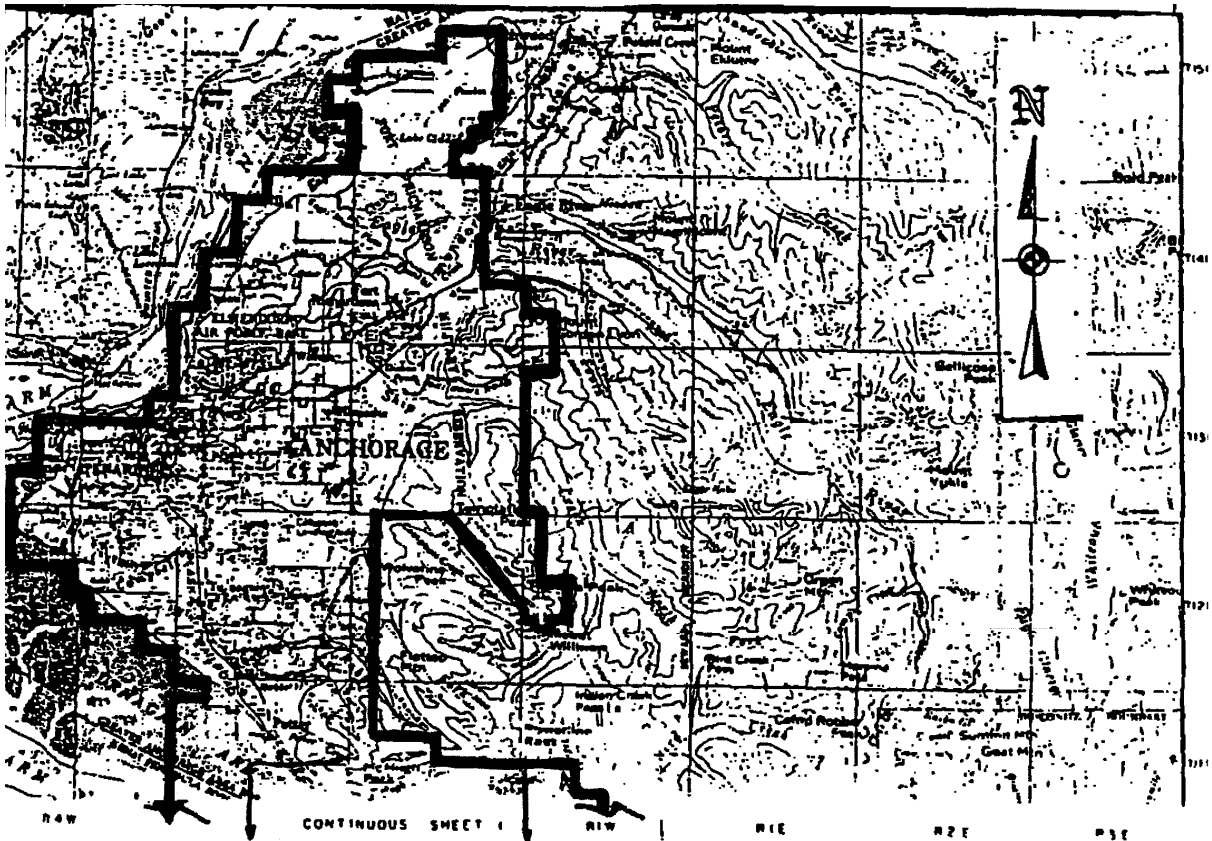

Tariff Advice No. 11-619

Effective: September 18, 2009

Issued By: Alaska Fiber Star, LLC.

By: *Lisa Phillips*
Lisa Phillips

Title: Manager, Regulatory Affairs

RCA No. 619

Original

Sheet No. x

Canceling

Sheet No.

Alaska Fiber Star, LLC.

ANCHORAGE SERVICE AREA MAP

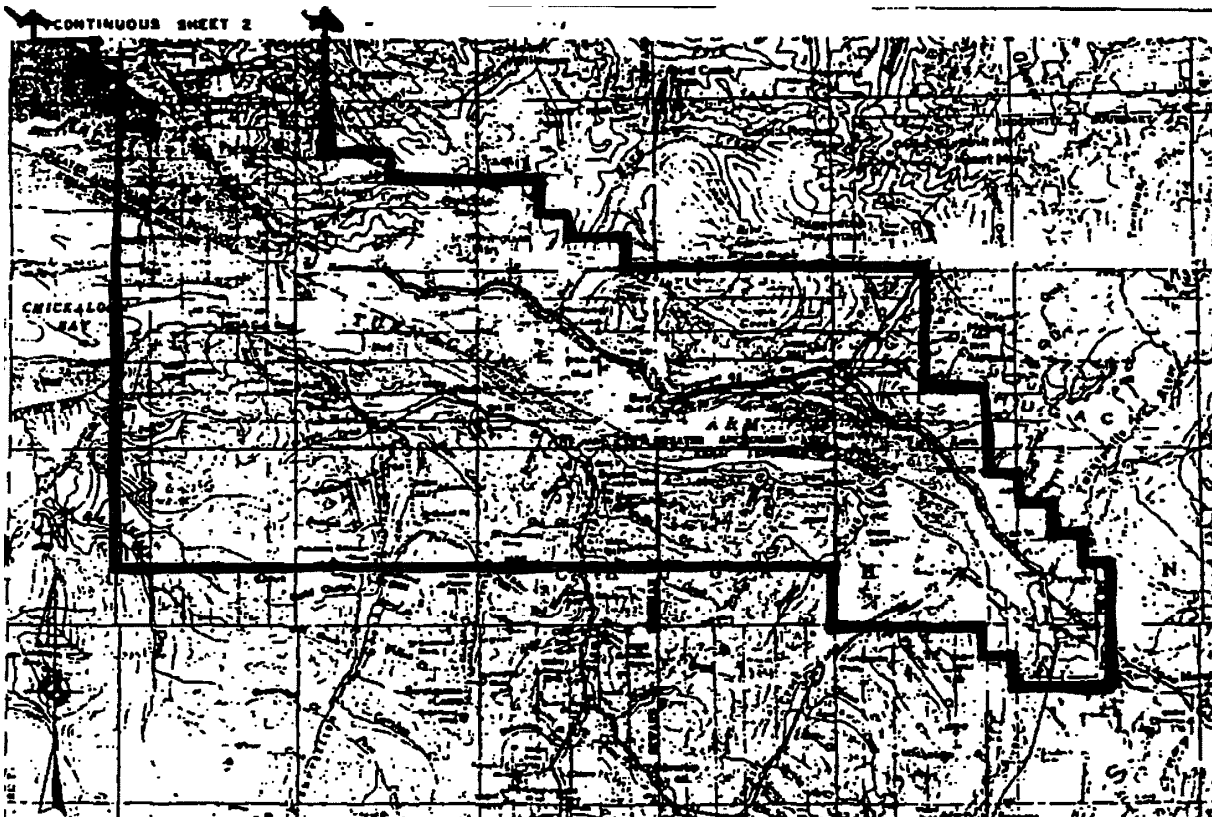

Tariff Advice No. 11-619

Effective: September 18, 2009

Issued By: Alaska Fiber Star, LLC.

By: *Lisa Phillips*
Lisa Phillips

Title: Manager, Regulatory Affairs

RCA No. 619

Original

Sheet No. xi

Canceling

Sheet No.

Alaska Fiber Star, LLC.

ANCHORAGE SERVICE AREA MAP

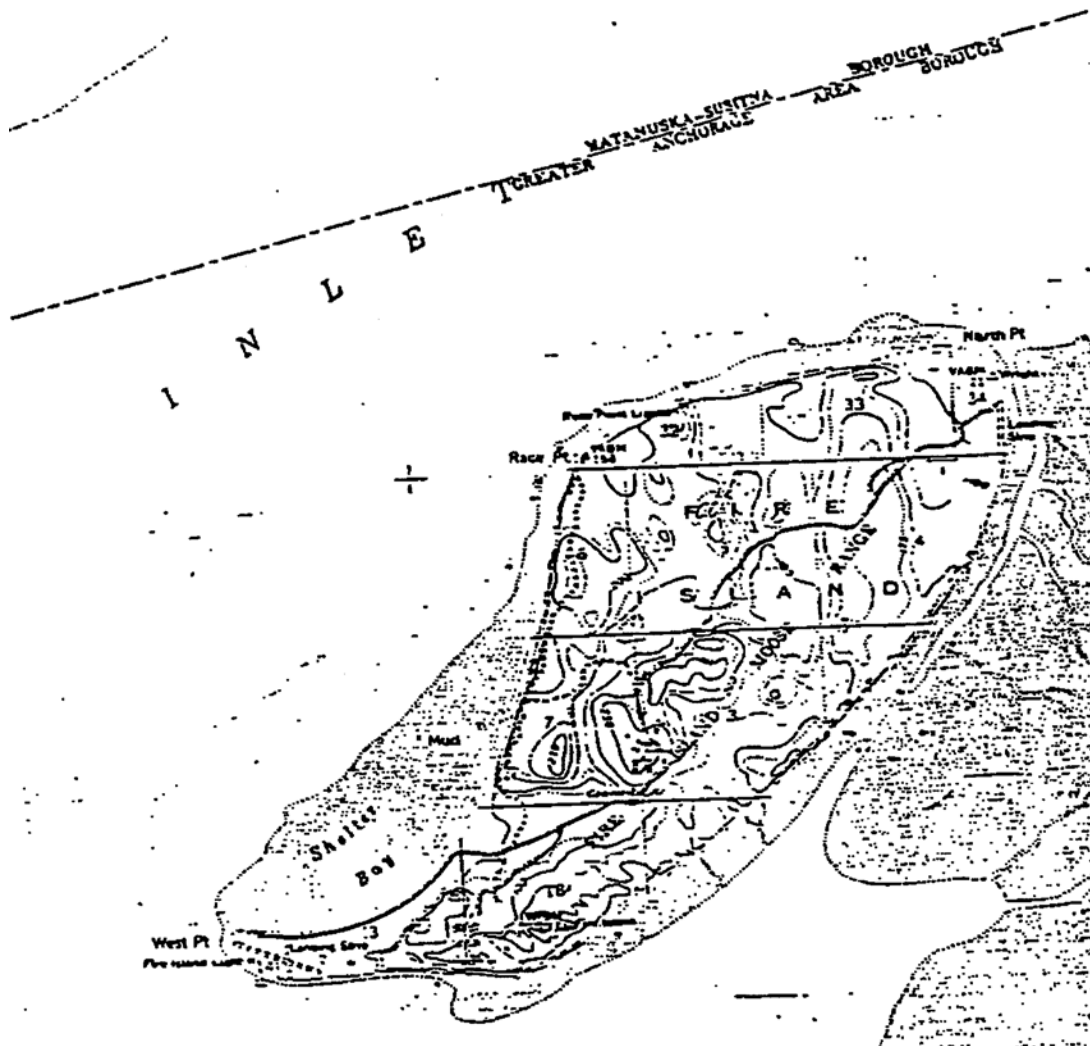

Tariff Advice No. 11-619

Effective: September 18, 2009

Issued By: Alaska Fiber Star, LLC.

By: *Lisa Phillips*
Lisa Phillips

Title: Manager, Regulatory Affairs

RCA No. 619	Original	Sheet No. xii	
	Canceling	Sheet No.	
Alaska Fiber Star, LLC.			
ANCHORAGE SERVICE AREA DESCRIPTION			
T15N	R3W	Section:	24
	R2W	Sections:	10, 11, 14 through 23, NW ¼ of 26; 27 through 33, and W ½ of 34
T14N	R3W	Sections:	1, 2, 11 through 23; 26 through 29, and 31 through 35
		Sections:	3, 9, 10, 15, 16, 20 through 23; 26 through 29, and 31 through 35
	R2W	Sections:	W ½ of 2; 3 through 10, W ½ of 11, W ½ of 14 West of the Old Glenn Highway, 15 through 22, W ½ of 23; 25 through 36
	R1W	Section:	31
T13 N	R5W	Sections	32 through 34
	R4W	Sections:	13, 20 through 29, 31 through 36
	R3W	Sections:	All
	R2W	Sections:	All
	R1W	Section:	6
T12N	R6W	Sections:	13, 14
	R5W	Sections:	4 through 9, 17 and 18
	R4W	Sections:	1 through 16 and 22 through 25
	R3W	Sections:	All
Tariff Advice No. 11-619		Effective: September 18, 2009	

Issued By: Alaska Fiber Star, LLC.

By: 
 Lisa Phillips

Title: Manager, Regulatory Affairs

RCA No. 619	Original	Sheet No. xiii	
	Canceling	Sheet No.	
Alaska Fiber Star, LLC.			
ANCHORAGE SERVICE AREA DESCRIPTION			
R2W	Sections:	1, 2, N ½ of NE ¼ and SE ¼ of NE ¼ of 3; 6, 7, NE ¼ of NW ¼ and N ½ of SE ¼ and SE ¼ of SE ¼ of 11; 12, NE ¼ and N ½ of NW ¼ and SE ¼ of NW ¼ and 1 ½ or SE ¼ and SE ¼ of SE ¼ of 13; 18, 19, NE ¼ of 20	
R1W	Sections:	W ½ of 6, W1/2 of 7, SW ¼ of 17, W ½ and SE ¼ of 18, N ½ and SE ¼ and NE ¼ of SW ¼ of 19, NW ¼ of 20	
T11N	R3W	Sections:	1 through 5, and 7 through 36
	R2W	Sections:	6, 7, and 16 through 36
	R1W	Sections:	19, 20, 28 through 35
T10N	R3W	Sections:	All
	R2W	Sections:	All
	R1W	Sections:	All
	R1E	Sections	All
	R2E	Sections	4 through 9, 16 through 21, and 26 through 35
R9N	R3W	Sections:	1 through 24
	R2W	Sections:	1 through 24
	R1W	Sections:	1 through 24
	R1E	Sections:	1 through 24
	R2E	Sections:	18, 19, 20, and 28 through 33
Tariff Advice No. 11-619		Effective: September 18, 2009	

Issued By: Alaska Fiber Star, LLC.

By: 
 Lisa Phillips

Title: Manager, Regulatory Affairs

RCA No. 619	Original	Sheet No. xiv	
	Canceling	Sheet No.	
Alaska Fiber Star, LLC.			
ANCHORAGE SERVICE AREA DESCRIPTION			
T8N	R2E	Section:	1
	R3E	Sections:	4 through 9
<p>Begich-Boggs Visitor Center and the Portage Glacier Lodge, both located in the Portage Valley Area.</p> <p>All of the above descriptions are in reference to the Seward Meridian and Seward base line.</p>			
Tariff Advice No. 11-619			Effective: September 18, 2009

Issued By: Alaska Fiber Star, LLC.

By: 
 Lisa Phillips

Title: Manager, Regulatory Affairs

RCA No. 619	Original	Sheet No. xv	
	Canceling	Sheet No.	
Alaska Fiber Star, LLC.			
EXPLANATION of SYMBOLS			
C	Denotes a changed condition or regulation.		
D	Denotes a discontinued rate, regulation, or condition.		
I	Denotes an increased rate or new treatment resulting in increased rates.		
L	Denotes material has been relocated from one sheet to another with no change in text, rate, rule, or condition.		
N	Denotes a new rate, regulation, condition, or sheet.		
R	Denotes a reduced rate or new treatment resulting in reduced rates.		
S	Denotes reissued material.		
T	Denotes a change in text for clarification.		
Tariff Advice No. 11-619		Effective: September 18, 2009	

Issued By: Alaska Fiber Star, LLC.

By: 
 Lisa Phillips

Title: Manager, Regulatory Affairs

RCA No. 619	Original	Sheet No. 1.1	
	Canceling	Sheet No.	
Alaska Fiber Star, LLC.			
PART I – DEFINITION of TERMS			
<p><u>Access Connection</u>: The term “Access Connection” denotes a service that connects a local channel and/or another local access at a Company point of Connection.</p> <p><u>Access Point</u>: The term “Access Point” denotes a Company facility location where service either begins or ends.</p> <p><u>Add/Drop Multiplexing</u>: The term “Add/Drop Multiplexing” denotes a multiplexing function that allows lower speed digital channels to be added or dropped from a high speed optical carrier channel in a wire center or other location. The connection to the add/drop multiplexer is via a channel to a Central Office Port at a specific digital speed (for example. DS1, DS3, etc.).</p> <p><u>Authorized User</u>: The term “Authorized User” denotes a person, firm, or corporation who is authorized by the Customer to be connected to the service of the Customer.</p> <p><u>Automatic Protection Switching</u>: The term “Automatic Protection Switching” denotes switching architecture designed for SONET to perform error protections and network management from any point on the SONET signal path.</p> <p><u>Bandwidth</u>: The term “Bandwidth” denotes (1) the range of transmission frequencies that a communication channel is capable of carrying without excessive attenuation, (2) the range of transmission speeds that a communication channel is capable of carrying without excessive errors. In digital communications, bandwidth is typically measured in bits per second (bps).</p> <p><u>Bit</u>: The term “Bit” denotes the smallest unit of information in the binary system of notation.</p> <p><u>Bridge</u>: The term “Bridge” denotes circuitry used to interconnect a network with a common set of higher level protocols.</p> <p><u>Business Day</u>: The term “Business Day” denotes the times of day that a Company is open for business. Generally accepted business hours are 8:00 or 9:00 a.m. to 5:00 or 6:00 p.m., respectively, with an hour for lunch, Monday through Friday, resulting in a standard 40 hour work week.</p>			
Tariff Advice No. 11-619		Effective: September 18, 2009	

Issued By: Alaska Fiber Star, LLC.

By: 
 Lisa Phillips

Title: Manager, Regulatory Affairs

RCA No. 619	Original	Sheet No. 1.2	
	Canceling	Sheet No.	
Alaska Fiber Star, LLC.			
PART I – DEFINITION of TERMS			
<p><u>Channel</u>: The term “Channel” denotes a path for communications between two or more combinations of stations or access points furnishing in such a manner as the Company may elect, whether by fiber, wire, terrestrial radio, satellite, or a combination thereof, and whether or not by means of a single physical facility or route capable of being accessed at a station or access point or by an external service adapter.</p> <p><u>Channel Capacity</u>: The term “Channel Capacity” denotes the measure of the digital bandwidth being sold, stated in Gigabits per second (Gbps), Megabits per second (Mbps), or Bits (bps).</p> <p><u>Channel Mileage Facility</u>: The term “Channel Mileage Facility” denotes a rate element associated with special access service. It relates to the transmission facilities between wire center, measured in miles, utilized in a special access configuration.</p> <p><u>Channel Mileage Termination</u>: The term “Channel Mileage Termination” denotes a rate element associated with special access service. It relates to the central office equipment terminations between wire centers utilized in a private line configuration.</p> <p><u>Channel Termination</u>: The term “Channel Termination” is a rate element associated with special access service. It related to the facilities and terminations at the Customer designated premises and the serving wire center utilized in a special access configuration.</p> <p><u>Commission</u>: The term “Commission” means the Regulatory Commission of Alaska (RCA).</p> <p><u>Company</u>: The term “Company” refers to Alaska Fiber Star, LLC. (AFS).</p> <p><u>Communications System</u>: The term “Communications System” denotes channels, bandwidth, and other facilities which are capable of communications between terminal equipment provided either by the Company or by other than the Company.</p>			
Tariff Advice No. 11-619		Effective: September 18, 2009	

Issued By: Alaska Fiber Star, LLC.

By: 
 Lisa Phillips

Title: Manager, Regulatory Affairs

RCA No. 619	Original	Sheet No. 1.3	
	Canceling	Sheet No.	
Alaska Fiber Star, LLC.			
PART I – DEFINITION of TERMS			
<p><u>Customer</u>: The term “Customer” denotes the person, firm, or corporation which orders service and is responsible for the payment of charges and compliance with the Company’s regulations.</p> <p><u>Customer Designated Premises (CDP)</u>: The term “CDP” denotes the area occupied by a Customer in a building or buildings on continuous property (except railroad rights-of-way, etc.) not separated by a public highway.</p> <p><u>Customer Node</u>: The term “Customer Node” denotes Company-provided equipment located at a customer designated premises that terminates a high speed optical channel.</p> <p><u>Customer Owned and Maintained Equipment (COAME)</u>: The term “COAME” denotes any device, apparatus, or wiring provided by the Customer for which complete ownership and maintenance responsibility resides with the Customer. The Company’s liability is limited to interconnection in accordance with the rules and regulations outlined elsewhere in this Tariff or as provided under a separate written agreement.</p> <p><u>Disconnection</u>: The term “Disconnection” denotes a complete blocking from the network.</p> <p><u>Facilities</u>: The term “Facilities” denotes instrumentalities, supplemental equipment, apparatus, wiring, poles, cables, and other materials and mechanisms necessary to, or furnished in connection with, telephone service.</p> <p><u>Fiber Optic</u>: The term “Fiber Optic” denotes a thin filament of glass with a protective outer coating through which a light beam carrying communications signals may be transmitted by means of multiple internal reflections to a receiver which translates the message.</p> <p><u>Gbps (Gigabits per second)</u>: The term “Gbps” denotes a bit rate expressed in thousands of Mbps.</p> <p><u>Hertz</u>: The term “Hertz” denotes a frequency unit equivalent to one cycle per second.</p>			
Tariff Advice No. 11-619		Effective: September 18, 2009	

Issued By: Alaska Fiber Star, LLC.

By: 
 Lisa Phillips

Title: Manager, Regulatory Affairs

RCA No. 619	Original	Sheet No. 1.4	
	Canceling	Sheet No.	
Alaska Fiber Star, LLC.			
PART I – DEFINITION of TERMS			
<p><u>Hub</u>: The term “Hub” denotes a Company-designated serving wire center at which bridging or multiplexing functions are performed.</p> <p><u>Kbps (Kilobits per second)</u>: The term “Kbps” denotes a bit rate expressed in thousands of bits per second.</p> <p><u>Mbps (Megabits per second)</u>: The term “Mbps” denotes a bit rate expressed in millions of bits per second.</p> <p><u>Originating Destination</u>: The term “Originating Destination” denotes the use of service for the origination of calls from an end user’s premises to the access point on the Customer’s premises.</p> <p><u>Other Line Facilities</u>: The term “Other Line Facilities” or “Other Facilities” denotes facilities that are not owned, leased, or operated by the Company.</p> <p><u>Service Adapter</u>: The term “Service Adapted” denotes a device or equipment which allows a Customer to access electrical and/or digital communications.</p> <p><u>Service Interruption</u>: The term “Service Interruption” denotes any condition when a service becomes unusable to the Customer because of a failure of a facility component used to furnish service by AFS, or when protective controls applied by AFS result in a complete loss of service to the Customer.</p> <p><u>Service Point</u>: The term “Service Point” denotes a place at which a Customer’s station is located, or a place via which traffic is routed at the request of the Customer.</p> <p><u>Services</u>: The term “Services” denotes special access, packet-switched, circuit-switched, and other data services offered pursuant to this Tariff.</p> <p><u>Serving Wire Center</u>: The term “Serving Wire Center” denotes the wire center from which the CPD accesses the services under this Tariff.</p>			
Tariff Advice No. 11-619			Effective: September 18, 2009

Issued By: Alaska Fiber Star, LLC.

By: 
 Lisa Phillips

Title: Manager, Regulatory Affairs

RCA No. 619	Original Canceling	Sheet No. 1.5 Sheet No.	
Alaska Fiber Star, LLC.			
PART I – DEFINITION of TERMS			
<p><u>Station</u>: The term “Station” denotes a point where service is provided.</p> <p><u>Subscriber</u>: The term “Subscriber” denotes the person in whose name service is furnished as evidenced by the signature on the application or contract for that service, or in the absence of a signed instrument, by the receipt and payment of bills regularly issued in his name, regardless of the identity of the actual user of the service (see also Customer).</p> <p><u>Tariff</u>: The term “Tariff” denotes the document which contains the rates, charges, rules, and regulations adopted and filed by the Company and approved by the Regulatory Commission of Alaska.</p> <p><u>Termination</u>: The term “Termination” denotes the discontinuance, either at the request of the Customer or by the Company under its regulations concerning cancellation for cause, of service or facilities provided by the Company.</p>			
Tariff Advice No. 11-619		Effective: September 18, 2009	

Issued By: Alaska Fiber Star, LLC.

By: 
 Lisa Phillips

Title: Manager, Regulatory Affairs

RCA No. 619	Original	Sheet No. 2.1	
	Canceling	Sheet No.	
Alaska Fiber Star, LLC.			
PART II – GENERAL RULES and REGULATIONS			
<p>A. <u>Application of Regulations</u></p> <p>The regulations set forth herein apply to intrastate services and facilities furnished within the State of Alaska by Alaska Fiber Star, LLC, hereinafter referred to as AFS or the Company, subject to the jurisdiction of the Regulatory Commission of Alaska, hereinafter referred to as the Commission.</p> <p>No officer, employee, or agent of the Company has authority to change, amend, or waive any rate or regulation approved or prescribed by the Commission. Rates and regulations may be changed or cancelled only with the consent or approval of the Commission.</p> <p>The Company furnishes special access, packet switched, and other data services, hereinafter referred to as AFS services or services, throughout the territory it serves, as shown by its filed rates, regulations, and maps. The Company also furnishes interexchange service to the territory served by connecting companies, subject to their rates and regulations.</p> <p>B. <u>Applicability of Tariff Rates</u></p> <p>The rates for services provided by the Company that are identified within this Tariff are for services regulated by the Commission.</p> <p>This Tariff is maintained at the location listed below for public inspection during normal business hours.</p> <p style="text-align: center;">Alaska Communications Systems 600 Telephone Avenue Anchorage, AK 99503</p>			
Tariff Advice No. 11-619		Effective: September 18, 2009	

Issued By: Alaska Fiber Star, LLC.

By: 
 Lisa Phillips

Title: Manager, Regulatory Affairs

RCA No. 619	Original	Sheet No. 2.2	
	Canceling	Sheet No.	
Alaska Fiber Star, LLC.			
PART II – GENERAL RULES and REGULATIONS			
<p>C. <u>Undertaking of the Customer</u></p> <p>1. Use</p> <p>a. AFS services may be used for one or more of the following purposes:</p> <p>1) For the transmission of communications to or from the Customer and relating directly to the Customer’s business;</p> <p>2) For the use by the Customer and for resale to others subject to applicable law.</p> <p>b. Company services shall not be used for an unlawful purpose.</p> <p>c. Company services are furnished subject to the condition that there will be no abuse or fraudulent use of these services as defined in this Tariff.</p> <p>d. Tampering with Equipment</p> <p>Customers or their agents may not install, rearrange, disconnect, or remove, or permit others to install, rearrange, disconnect, or remove any equipment or wiring that is the property of the Company. The Company shall have the right to charge the Customer the Tariff rate for any installations or rearrangements made of Company-owned equipment. The Company may refuse to furnish or may deny service to any person, firm, or corporation on whose premises is located any Company-owned telephone equipment which shows any evidence of tampering, manipulations, or operation, or use of any device whatsoever for the purpose of obtaining service without payment of the charge applicable.</p>			
Tariff Advice No. 11-619		Effective: September 18, 2009	

Issued By: Alaska Fiber Star, LLC.

By: 
 Lisa Phillips

Title: Manager, Regulatory Affairs

RCA No. 619	Original	Sheet No. 2.3	
	Canceling	Sheet No.	
Alaska Fiber Star, LLC.			
PART II – GENERAL RULES and REGULATIONS			
<p>C. <u>Undertaking of the Customer</u> (cont.)</p> <p>1. Use (cont.)</p> <p>e. Unauthorized Attachments or Connections</p> <p>No equipment, apparatus, circuit, or device not furnished by the Company shall be attached to or connected with the facilities furnished by the Company, whether physically, by induction, or otherwise, except as provided elsewhere in the Tariff of the Company. In case any such unauthorized attachment or connection is made, the Company shall have the right to remove or disconnect the same; or to suspend the service during the period the attachment is made; or to terminate the service.</p> <p>2. Resale</p> <p>When services are resold, the Customer may advise its authorized user that a portion of its service is provided by the Company. However, the Customer shall not represent that the Company jointly participates with the Customer in the provision of its services.</p> <p>3. Identification of Employees</p> <p>Employees of the Company or an underlying carrier, whose duties require them to enter premises of customer, carry identifications cards. To verify employment during regular business hours call the Company.</p>			
Tariff Advice No. 11-619		Effective: September 18, 2009	

Issued By: Alaska Fiber Star, LLC.

By: 
 Lisa Phillips

Title: Manager, Regulatory Affairs

RCA No. 619	Original Canceling	Sheet No. 2.4 Sheet No.	
Alaska Fiber Star, LLC.			
PART II – GENERAL RULES and REGULATIONS			
<p>C. <u>Undertaking of the Customer</u> (cont.)</p> <p>4. Engineering, Installation, and Maintenance</p> <p>The Company fully supports its services provided over its own facilities and under this Tariff through engineering, installation, and maintenance efforts. The Company will assure that the service is provides over its facilities function properly within specified transmission and signaling parameters. Services provisioned using facilities of other carriers will be provided according to the specifications of the underlying carriers. The maintenance policies and standards described in this sections pertain to the Company's own facilities.</p> <p>a. Maintenance Concept</p> <p>The Company has established a comprehensive maintenance program to ensure that the network continually meets established performance standards. This concept includes policies and procedures designed to plan, schedule, and implement physical surveillance, preventative maintenance checks and services, and perform unscheduled restoration of both the inside and outside plant should a service interruption occur.</p> <p>b. Remote Alarm Surveillance</p> <p>The Company will provide remote alarm surveillance and sectionalization equipment and procedures for the purpose of detecting any out-of-service conditions or service affecting conditions, and for rapidly removing service impairments and restoring services.</p>			
Tariff Advice No. 11-619		Effective: September 18, 2009	

Issued By: Alaska Fiber Star, LLC.

By: 
 Lisa Phillips

Title: Manager, Regulatory Affairs

RCA No. 619	Original	Sheet No. 2.5	
	Canceling	Sheet No.	
Alaska Fiber Star, LLC.			
PART II – GENERAL RULES and REGULATIONS			
<p>C. <u>Undertaking of the Customer</u> (cont.)</p> <p>4. Engineering, Installation, and Maintenance (cont.)</p> <p>c. Notification</p> <p>In the event of any service affecting alarm condition, the Company will attempt to notify the designated Customer reporting number within 15 minutes of the occurrence of such alarm. This notice will include the type and status of each alarm, the estimated time to repair and the probably cause of failure. The Company will continue to periodically report the status of repair work and a revised estimate of time required until repairs have been made and service restored.</p> <p>d. Restoral of Service</p> <p>Immediately upon the occurrence of an alarm or service-affecting condition or service interruption, the Company shall notify appropriate maintenance personnel and commence to isolate and repair the underlying cause or fault.</p> <ul style="list-style-type: none"> • <u>Standard Facility Path</u>: The Company will respond remotely to immediately diagnose the location and nature of the fault. The goal is to effect repairs to restore service. When restoral of the outage requires on-site response, technical teams will be mobilized and dispatched to the point of failure by the most expeditious means. • <u>Restoral Prioritization</u>: In the event of more than one service interruption at any given time, the Company shall, with the Customer's cooperation, determine the order in which the services are to be restored. It is the responsibility of the customer to initiate the request for restoration prioritization. 			
Tariff Advice No. 11-619			Effective: September 18, 2009

Issued By: Alaska Fiber Star, LLC.

By: 
 Lisa Phillips

Title: Manager, Regulatory Affairs

RCA No. 619	Original Canceling	Sheet No. 2.6 Sheet No.	
Alaska Fiber Star, LLC.			
PART II – GENERAL RULES and REGULATIONS			
<p>C. <u>Undertaking of the Customer</u> (cont.)</p> <p>5. Through Transmission of Signals</p> <p>The Company is responsible for engineering, operating, and maintaining the services it provides. It is also responsible for the provision of these services at the appropriate industry standard.</p> <p>6. Monitoring and Reporting</p> <p>The Company will monitor and report systems performance per network equipment capabilities to ensure that the services meet or exceed the standards indicated in the following section.</p> <p>7. Performance Standards and Transmission Specifications</p> <p>Applicable industry standards include, but are not limited to:</p> <ul style="list-style-type: none"> • ANSI T1.123-1993 / Telecommunications – Digital Hierarchy – Layer 1 In-Service Digital Transmission Performance Monitoring; • ANSI T1.510-1994 / Telecommunications Network Performance Parameters for Dedicated Digital Services – Specification. 			
Tariff Advice No. 11-619		Effective: September 18, 2009	

Issued By: Alaska Fiber Star, LLC.

By: 
 Lisa Phillips

Title: Manager, Regulatory Affairs

RCA No. 619	Original Canceling	Sheet No. 2.7 Sheet No.	
Alaska Fiber Star, LLC.			
PART II – GENERAL RULES and REGULATIONS			
<p>D. <u>Limitation of Liability</u></p> <p>The Company will make a good faith effort to provide the services offered in this Tariff. However, due to the unavailability to errors incident to the services and the use of such facilities of the Company are subject to the following terms, conditions, and limitations.</p> <ol style="list-style-type: none"> 1. The liability of the Company for damages arising out of mistakes, omissions, service interruptions, delays, errors, or defects in transmission occurring in the course of furnishing service shall in no event exceed an amount equivalent to the proportionate charge to the Customer for the period during which such mistake, omission, service interruption, delay, error, or defect in transmission occurs. 2. The Company’s liability shall be limited as set forth above for loss or damage of any kind whatsoever to the Customer in connection with AFS services, and/or equipment including, without limitation, loss or damage caused by service interruptions, omissions, delays, errors, or defects in the services, and/or equipment, which arise from circumstances beyond its control including, without limitations, a Force Majeure event. The Company shall under no circumstances be liable for loss or damage of any kind whatsoever to the Customer which arises from acts or omissions of other persons who are not agents or employees of the Company. <p>The Company shall not be liable for any damages whatsoever associated with service, facilities, or equipment which the Company does not furnish or for any act of omission of Customer or any other entity furnishing services, facilities, or equipment used for or in conjunction with Alaska Fiber Star.</p>			
Tariff Advice No. 11-619		Effective: September 18, 2009	

Issued By: Alaska Fiber Star, LLC.

By: 
 Lisa Phillips

Title: Manager, Regulatory Affairs

RCA No. 619	Original	Sheet No. 2.8	
	Canceling	Sheet No.	
Alaska Fiber Star, LLC.			
PART II – GENERAL RULES and REGULATIONS			
<p>D. <u>Limitation of Liability (cont.)</u></p> <p>The Customer agrees that for any breach by the Company hereunder, no remedy against the Company or any of its affiliated companies for incidental or consequential damages (including, but not limited to, damages for lost profits, lost sales, injury to persons or property, or any other incidental or consequential loss) shall be available to the Customer absent willful misconduct or gross negligence on the part of the Company.</p> <p>E. <u>Other Provisions and Limitations</u></p> <p>1. Indemnification</p> <p>The Customer shall indemnify and hold harmless the Company and its affiliates and any of their respective directors, officers, employees, agents, and assigns from and against the following and each such indemnity shall survive termination of services:</p> <p>a. Any and all losses, liability, damage, and expense, including attorney fees, incurred or suffered by the Company arising out of any misrepresentations or breach of warranty, covenant, or agreement made or to be performed by the Customer pursuant to this Agreement;</p> <p>b. Any and all losses, liability, damage, and expense, including attorney fees, dues to (i) claims for libel, slander, or infringement of copyright or trademark in connection with any material transmitted by the Customer using the Company’s telecommunications or other services or (ii) claims for patent infringement arising from combining with or using in connection with facilities furnished by the Company, apparatus, and systems owned or controlled by the Customer;</p>			
Tariff Advice No. 11-619		Effective: September 18, 2009	

Issued By: Alaska Fiber Star, LLC.

By: 
 Lisa Phillips

Title: Manager, Regulatory Affairs

RCA No. 619	Original Canceling	Sheet No. 2.9 Sheet No.	
Alaska Fiber Star, LLC.			
PART II – GENERAL RULES and REGULATIONS			
<p>E. <u>Other Provisions and Limitations</u> (cont.)</p> <p>1. Indemnification (cont.)</p> <p>c. Any and all losses, claims, demands, suits or other actions, or any liability, damage and expense, including attorney’s fees, whether suffered, made, instituted, or asserted by the Customer or by any other party or persons, for any personal injury to or death of any person or persons, and for any loss, damage, or destruction of any property, whether owned by the Company, the Customer or others, caused or claimed to have been caused directly or indirectly by the installation, operation, failure to operate, maintenance, removal, presence, condition, location, or use of the equipment, any equipment owned or controlled by the Company or any of its affiliates;</p> <p>d. All charges for services and equipment ordered by the Customer from other entities for telecommunications services, equipment, or facilities connecting the Customer and the Company; and</p> <p>e. Any and all losses, claims, demands, suits or other action, or any liability, damage and expense including attorney’s fees, arising out of any unlawful or unauthorized use of the Company’s facilities or services.</p>			
Tariff Advice No. 11-619		Effective: September 18, 2009	

Issued By: Alaska Fiber Star, LLC.

By: 
 Lisa Phillips

Title: Manager, Regulatory Affairs

RCA No. 619	Original Canceling	Sheet No. 2.10 Sheet No.	
Alaska Fiber Star, LLC.			
PART II – GENERAL RULES and REGULATIONS			
<p>E. <u>Other Provisions and Limitations</u> (cont.)</p> <p>1. Indemnification (cont.)</p> <p> If a third party notifies the Company or its affiliates or any of their directors, officers, employees, agents, or assigns (the “Indemnified Party”) of a claim (a “Third Party Claim”) which gives rise to a right of indemnification against the Customer, then within 10 business days after receipt of the notice of the Third Party Claim from the Indemnified Party, the Customer shall give notice to the Indemnified Party stating whether or not the Customer will assume the defense of such Third Party Claim. If the Customer assumes the defense of such Third Party Claim, then the Customer shall pay all costs and expenses (including, thought limitations, fees and disbursements of counsel) in connection with the Third Party Claim, and any counsel employed by the Customer in connection therewith shall be satisfactory to the Indemnified Party. If the Customer fails to give notice to the Indemnified Party that the Customer assumes the defense of the Third Party Claim, then the Indemnified Party shall have the right to undertake the defense, compromise, or settle such Third Party Claim and all costs and expenses (including, without limitations, reasonable attorneys’ fees and disbursements) incurred by the Indemnified Party in connection with such Third Party Claim shall be paid to the Indemnified Party by the Customer as such costs and expenses become due. The Customer shall not compromise or settle any Third Party Claim or consent to the entry to any judgment with respect to any Third Party Claim, without the prior written consent of the Indemnified Party, which consent shall not be unreasonably withheld.</p>			
Tariff Advice No. 11-619		Effective: September 18, 2009	

Issued By: Alaska Fiber Star, LLC.

By: 
 Lisa Phillips

Title: Manager, Regulatory Affairs

RCA No. 619	Original Canceling	Sheet No. 2.11 Sheet No.	
Alaska Fiber Star, LLC.			
PART II – GENERAL RULES and REGULATIONS			
<p>E. <u>Other Provisions and Limitations</u> (cont.)</p> <p>2. Acts or Omissions</p> <p> The Company is not liable for any act or omission of any other company or companies, including an underlying carrier, if any, furnishing a portion of the services.</p> <p>3. Limitation on Warranty</p> <p> a. The rates for the services set forth in this Tariff are determined on the basis of the disclaimers or warranties and the limitations of liability contained in this Tariff.</p> <p> b. Neither the Company nor any of its affiliated companies make nor have made any other warranty, expressed or implied, as to any of the particulars, fitness or a particular purpose, usage or trade, or merchantability of the Company services. Except as is set forth in this Tariff or any agreement, no oral or written statements of representatives of the Company including but not limited to salespersons, reports or conditions or tests, specifications, or other information not set forth herein which the Company may have given to the Customer shall be deemed to be warranties or representations of the Company.</p>			
Tariff Advice No. 11-619		Effective: September 18, 2009	

Issued By: Alaska Fiber Star, LLC.

By: 
 Lisa Phillips

Title: Manager, Regulatory Affairs

RCA No. 619	Original	Sheet No. 2.12	
	Canceling	Sheet No.	
Alaska Fiber Star, LLC.			
PART II – GENERAL RULES and REGULATIONS			
<p>E. <u>Other Provisions and Limitations</u> (cont.)</p> <p>4. Defacement or Damage to Premises</p> <p>The Company is not liable for any defacement of or damage to the premises of a Customer (or authorized user) resulting from the furnishing of services and/or facilities or the attachment of the apparatus and associated wiring furnished by the Company on such premises or the installation or removal thereof, when such defacement or damage is not the result of negligence of the agents or employees of the Company.</p> <p>5. Intellectual Property</p> <p>No license under patents (other than limited license to use) is granted by the Company of shall be implied or arise by estoppel with respect to the services offered pursuant to this Tariff.</p> <p>6. Force Majeure</p> <p>A Force Majeure event constitutes any circumstances beyond the control of the Company, including, but not limited to: acts of God or of the public enemy, acts of the United States Government, fire, flood, earthquakes, other natural disasters, epidemics, quarantines, strikes, embargoes, or preemption of existing services to restore service in compliance with applicable rules and regulations of the Federal Communications Commission. The Customer may not, by reason of any service interruption, omission, delay, error or defect in the services, rescind, modify, or terminate any services under any legal or equitable theory where the service interruption, omission, delay, error or defect in the services is the result of a Force Majeure even provided that:</p>			
Tariff Advice No. 11-619		Effective: September 18, 2009	

Issued By: Alaska Fiber Star, LLC.

By: 
 Lisa Phillips

Title: Manager, Regulatory Affairs

RCA No. 619	Original Canceling	Sheet No. 2.13 Sheet No.	
Alaska Fiber Star, LLC.			
PART II – GENERAL RULES and REGULATIONS			
<p>E. <u>Other Provisions and Limitations</u> (cont.)</p> <p>6. Force Majeure (cont.)</p> <p>a. The Company shall, as soon as practicable, notify the Customer of its suspension of performance due to such Force Majeure event, which notice shall be confirmed in writing within 24 hours of such Force Majeure event if possible;</p> <p>b. The Company shall make a reasonable effort to minimize the effects of the even and to fully resume its performance; and</p> <p>c. The suspension of performance shall be of no greater scope and of no longer duration than is reasonably required by such Force Majeure event.</p> <p>A failure to perform by one of the Company’s subcontractors or suppliers or by an underlying carrier, if any, which results in any service interruption, omission, delay, error or defect in the services shall constitute a circumstance beyond the control of the Company.</p> <p>F. <u>Obligation of the Customer</u></p> <p>1. Application for Initial Service</p> <p>Initial applications for service may be made on the Company’s standard forms at the Company’s designated location(s) or by calling the Company’s customer service. Requests from Customers for additional services, equipment, etc., may be made orally or in writing and, upon approval or installation of service, become part of the original application.</p>			
Tariff Advice No. 11-619		Effective: September 18, 2009	

Issued By: Alaska Fiber Star, LLC.

By: 
 Lisa Phillips

Title: Manager, Regulatory Affairs

RCA No. 619	Original	Sheet No. 2.14	
	Canceling	Sheet No.	
Alaska Fiber Star, LLC.			
PART II – GENERAL RULES and REGULATIONS			
<p>F. <u>Obligation of the Customer</u> (cont.)</p> <p>2. Service Order</p> <p>Customers shall request Company services by submitting a service order. The service order shall contain details applicable to the specific services including the requested capacity, the service start date, the terms of service, and the amount of the deposit required. The terms and conditions of the Tariff shall apply to any service order accepted by the Company and to the service provided there under. However, the Company shall have no obligation to accept or to continue accepting service orders.</p> <p>3. Maintenance and Repairs</p> <p>The Company will bear all ordinary expense of maintenance and repair unless otherwise specified in this Tariff. In case of loss, damage, or destruction of any of the Company's equipment, not due to ordinary wear and tear, the Customer is held responsible for the cost of replacing the equipment destroyed, or the cost of restoring the equipment to its original condition.</p> <p>4. Ownership and Use of the Equipment</p> <p>Equipment and lines on the Customer's premises, furnished by the Company, shall be and remain the property of the Company, whose agents and employees have the right to enter said premises at any reasonable hour for the purpose of installing, inspecting, or repairing the equipment and lines, and, upon termination of the service, for the purpose of removing such equipment.</p>			
Tariff Advice No. 11-619		Effective: September 18, 2009	

Issued By: Alaska Fiber Star, LLC.

By: 
 Lisa Phillips

Title: Manager, Regulatory Affairs

RCA No. 619	Original Canceling	Sheet No. 2.15 Sheet No.	
Alaska Fiber Star, LLC.			
PART II – GENERAL RULES and REGULATIONS			
<p>F. <u>Obligation of the Customer</u> (cont.)</p> <p>5. Fraudulent and/or Illegal Use Prohibited</p> <p>The Customer shall not permit the abuse or the fraudulent and/or illegal use of any facilities owned by the Company. The Customer shall not permit the use of the Company’s services for:</p> <ul style="list-style-type: none"> a. any purpose which is in violation of applicable Federal or state laws or regulations; b. obtaining or attempting to obtain telecommunications service through any scheme, false representation, and/or use of any fraudulent means or devices whatsoever with the intent to avoid payment, in whole or in part, of rates and charges for telecommunications or other services, or assisting any other person or company in such regard; c. attempting to, or actually obtaining, accessing, altering, or interfering with the communications and/or information by rearranging, tampering with, or making any connection with any facilities of the Company’ d. interfering unreasonably with the use of the telecommunications services by one or more other customers; or e. conveying information which is prohibited by, or which results in liability, under Federal or state laws or regulations. 			
Tariff Advice No. 11-619		Effective: September 18, 2009	

Issued By: Alaska Fiber Star, LLC.

By: 
 Lisa Phillips

Title: Manager, Regulatory Affairs

RCA No. 619	Original	Sheet No. 2.16	
	Canceling	Sheet No.	
Alaska Fiber Star, LLC.			
PART II – GENERAL RULES and REGULATIONS			
<p>F. <u>Obligation of the Customer</u> (cont.)</p> <p>6. Reimbursement for Damages Required</p> <p>The Customer shall reimburse the Company for damages to facilities cause by any negligence or willful misconduct of the Customer as may be determined by a court or tribunal of appropriate jurisdiction. The Company will reasonably cooperate with the Customer in its subrogation claim against any third party causing such damage.</p> <p>7. Payment of Attorney’s Fees</p> <p>In the even a suit is brought by the Company, or an attorney is retained by the Company to collect any bill or enforce the terms of this Tariff against a Customer, that Customer shall be responsible for payment of all reasonable attorney’s fees, court costs, costs of investigation, and any and all other related costs and expenses incurred by the Company in connection therewith.</p> <p>8. Compliance with FCC Rules Required</p> <p>The Customer, not the Company, shall be responsible for compliance with FCC Rules, 47 C.F.R., Part 68, and for all maintenance of such equipment and/or facilities unless the Customer and the Company agree otherwise.</p> <p>9. Power Supply</p> <p>It is the responsibility of the Customer to provide a suitable supply of ac commercial power, including outlets, when and where the Company requires it for the operation of any equipment on the Customer’s premises. The customer may elect to supply 48 vdc power to the Company equipment by mutual agreement with the Company.</p>			
Tariff Advice No. 11-619		Effective: September 18, 2009	

Issued By: Alaska Fiber Star, LLC.

By: 
 Lisa Phillips

Title: Manager, Regulatory Affairs

RCA No. 619	Original Canceling	Sheet No. 2.17 Sheet No.	
Alaska Fiber Star, LLC.			
PART II – GENERAL RULES and REGULATIONS			
<p>F. <u>Obligation of the Customer</u> (cont.)</p> <p>10. Right of Access</p> <p>The Company or underlying carrier, through its authorized employees, shall have the right of access to a Customer’s premises to install, remove, inspect, or repairs its lines and equipment, at any reasonable hour.</p> <p>11. Customer Complaints</p> <p>a. General</p> <p>A complaint is referred to herein as a report or series of reports concerning service, a dispute concerning a billing or computation thereof, or any other contest concerning practices, charges, and/or services of the Company which has not been satisfactorily resolved within a reasonable amount of time. Routine trouble reports shall not be considered a complaint for application of this Tariff schedule.</p> <p>b. Submission of Complaint</p> <p>A complaint may be oral or in writing. However, the Company may require that the complaint be submitted in written form. All written complaints shall be sent to Alaska Fiber Star, c/o Alaska Communications Systems, 600 Telephone Avenue, Anchorage, AK 99503.</p>			
Tariff Advice No. 11-619		Effective: September 18, 2009	

Issued By: Alaska Fiber Star, LLC.

By: 
 Lisa Phillips

Title: Manager, Regulatory Affairs

RCA No. 619	Original Canceling	Sheet No. 2.18 Sheet No.	
Alaska Fiber Star, LLC.			
PART II – GENERAL RULES and REGULATIONS			
<p data-bbox="207 506 711 537">F. <u>Obligation of the Customer</u> (cont.)</p> <p data-bbox="305 573 740 604">11. Customer Complaints (cont.)</p> <p data-bbox="402 640 797 672">c. Disposition of Complaints</p> <p data-bbox="496 707 1414 1020">All complaints shall set forth the name, address, and telephone number of the complaining party, the nature of the complaint, supporting facts, including pertinent dates, and the remedy requested. Within 45 days of a written complaint's receipt, a letter of determination will be sent to the complainant. This letter of determination will, in general, state the subscriber's complaint, the Company's finding, any applicable Tariff text or Company policy, and any adjustment or action to be taken to resolve the complaint.</p> <p data-bbox="402 1058 1414 1129">If the complaint has not been resolved to the parties' satisfaction, further action can be taken by appeal to the Regulatory Commission of Alaska.</p>			
Tariff Advice No. 11-619		Effective: September 18, 2009	

Issued By: Alaska Fiber Star, LLC.

By: 
 Lisa Phillips

Title: Manager, Regulatory Affairs

RCA No. 619	Original	Sheet No. 2.19	
	Canceling	Sheet No.	
Alaska Fiber Star, LLC.			
PART II – GENERAL RULES and REGULATIONS			
<p>G. <u>Payments and Charges</u></p> <p>1. General</p> <p>The Customer is responsible for the payment of all charges for facilities and services furnished by the Company to the Customer and to all users authorized by the Customer, regardless of whether those services are used by the Customer itself or are resold or shared with other persons.</p> <p>2. Payment of Charges</p> <p>a. Monthly payments by the Customer shall be due within 25 days of the date of the bill. Customers shall make all payments as cleared funds or by bank check or by telegraphic transfer to the account nominated by the Company.</p> <p>b. Monthly recurring charges are billed to the Customer monthly in advance and non-recurring charges are billed in arrears.</p> <p>c. Interim or other special bills will be issued as required.</p> <p>d. If any monthly payment is not paid on the date specified in the service order, a one-time 1% late payment fee, plus interest at the rate of 0.0287% per day, calculated on the total payment due, will be charged and will begin to accrue on the day after the payment becomes due.</p> <p>e. A payment is not considered made until the payment is honored by a bank or other financial institution. A Customer's failure to make payments on the date due, regardless of the reason, will make available to the Company the remedies set forth in this Tariff including termination of the services.</p>			
Tariff Advice No. 11-619		Effective: September 18, 2009	

Issued By: Alaska Fiber Star, LLC.

By: 
 Lisa Phillips

Title: Manager, Regulatory Affairs

RCA No. 619	Original	Sheet No. 2.21	
	Canceling	Sheet No.	
Alaska Fiber Star, LLC.			
PART II – GENERAL RULES and REGULATIONS			
<p>G. <u>Payments and Charges</u> (cont.)</p> <p>3. Disputed Bills</p> <p>a. When the Customer disputes a bill for the Company’s service, the Customer shall (i) pay any undisputed portion of the bill and, at the Customer’s election, pay the disputed portion pending resolution of the dispute; (ii) advise the Company in writing that the bill or any portions thereof are disputed by the Customer; and (iii) provide a written explanation of the basis for the dispute within 30 days of the invoice date in question.</p> <p>b. The Company will review the Customer’s bill and notify the Customer within 30 days of the outcome of its review. If the Company agrees with the Customer, it shall credit the Customer’s account for any disputed amounts paid by the Customer. If the Company disagrees with the Customer, any disputed amount unpaid by the Customer shall become payable upon notice to the Customer.</p> <p>c. If there remains a disagreement about the disputed amount after investigation and review by the Company, the Customer may file an appropriate complaint with the Regulatory Commission of Alaska. The address of the Commission is:</p> <p style="text-align: center;">Regulatory Commission of Alaska 1016 West 6th Avenue, Suite 400 Anchorage, AK 99501-1063</p>			
Tariff Advice No. 11-619		Effective: September 18, 2009	

Issued By: Alaska Fiber Star, LLC.

By: 
 Lisa Phillips

Title: Manager, Regulatory Affairs

RCA No. 619	Original	Sheet No. 2.22	
	Canceling	Sheet No.	
Alaska Fiber Star, LLC.			
PART II – GENERAL RULES and REGULATIONS			
<p>G. <u>Payments and Charges</u> (cont.)</p> <p>3. Disputed Bills (cont.)</p> <p>d. If the Customer does not pay the disputed amount after a finding for the Company by the Commission, the Company may then disconnect the service. The Company may also disconnect the service after 3.b., above, if the Customer does not elect to file a complaint with the Commission.</p> <p>4. Notice of Discontinuance</p> <p>a. General</p> <p>The Company requires 30 days notice when services are to be discontinued. When a Customer requests discontinuance of services and the minimum service period for the particular service has not been met, the Customer must pay the amount that would be been paid through the minimum service period.</p> <p>b. Cancellation of Application for Service</p> <p>1) Where the Company permits the Customer to cancel an application for service prior to the service commencement date or prior to any special construction, no charges will be imposed except for those specified below.</p>			
Tariff Advice No. 11-619			Effective: September 18, 2009

Issued By: Alaska Fiber Star, LLC.

By: 
 Lisa Phillips

Title: Manager, Regulatory Affairs

RCA No. 619	Original	Sheet No. 2.23	
	Canceling	Sheet No.	
Alaska Fiber Star, LLC.			
PART II – GENERAL RULES and REGULATIONS			
<p>G. <u>Payments and Charges</u> (cont.)</p> <p>4. Notice of Discontinuance (cont.)</p> <p>b. Cancellation of Application for Service (cont.)</p> <p>2) Where, prior to cancellation by the Customer, the Company incurs any expenses in installing the service or in preparing to install the service that it would otherwise not have incurred, a charge equal to the costs the Company incurred, less net salvage, shall apply, but in no case shall this charge exceed the sum of the charge for the minimum period of service ordered, including installation charges, and all charges others levied against the Company that would have been chargeable to the Customer had service begun.</p> <p>3) Where the Company incurs any expense in connection with special construction, or where special arrangements of facilities or equipment have begun before the Company receives a cancellation notice, a charge equal to the costs incurred, less net salvage, may apply. In such cases, the charge will be based on such elements as the cost of the equipment, facilities, and material, the cost of installation, engineering, labor, and supervision, general and administrative expense, other disbursements, depreciation, maintenance, taxes, provision for return on investment, and any other costs associated with the special construction or arrangements.</p> <p>4) The special charge described in this section will be calculated and applied on a case-by-case basis.</p>			
Tariff Advice No. 11-619		Effective: September 18, 2009	

Issued By: Alaska Fiber Star, LLC.

By: 
 Lisa Phillips

Title: Manager, Regulatory Affairs

RCA No. 619	Original Canceling	Sheet No. 2.24 Sheet No.	
Alaska Fiber Star, LLC.			
PART II – GENERAL RULES and REGULATIONS			
<p>G. <u>Payments and Charges</u> (cont.)</p> <p>5. Deposits</p> <p>a. General</p> <p>The Company may, in order to safeguard its interests, require a Customer to make a suitable deposit, supply credit references acceptable to the Company, or provide a surety bond or letter of credit in the amount of the required deposit as a guarantee of the payment of charges. The Company shall have the right to require the Customer to make a deposit at the time of the application for service or at any time thereafter. The amount of the deposit required shall not exceed the equivalent of two months' billings for services requested, in accordance with 3 AAC 48.420.</p> <p>The fact that a deposit is made does not relieve the Customer from complying with the Company's regulations for payment of bills in accordance with the terms herein.</p> <p>b. Interest Paid on Deposit</p> <p>Interest on Customer deposits in excess of \$100.00 will be paid at the legal rate at the time the deposit is refunded. If the deposit is placed in an interest-bearing account, the Company will pay the interest rate of the interest-bearing account. No refunds under \$5.00 will be made unless requested by the Customer.</p>			
Tariff Advice No. 11-619		Effective: September 18, 2009	

Issued By: Alaska Fiber Star, LLC.

By: 
 Lisa Phillips

Title: Manager, Regulatory Affairs

RCA No. 619	Original	Sheet No. 2.25	
	Canceling	Sheet No.	
Alaska Fiber Star, LLC.			
PART II – GENERAL RULES and REGULATIONS			
<p>G. <u>Payments and Charges</u> (cont.)</p> <p>5. Deposits (cont.)</p> <p>c. Return of Deposit</p> <p>The Company will not retain the Customer’s deposit longer than two years unless the Customer has been delinquent in payment more than once in any 12 consecutive months or if the Company has been forced to terminate the Customer’s services for reasons of delinquency in payment of charges.</p> <p>Upon termination of service, the deposit will be credited to the Customer’s account and any credit balance will be refunded after all amounts due to the Company have been paid.</p> <p>6. Credit for Service Interruption</p> <p>a. Unless otherwise specified in this Tariff, credit for service interruptions will be allowed only when failure is cause by or occurs in the Company’s facilities or equipment owned, provided and billed for by the Company, for such period where the service is interrupted by the Company for access to its facilities for the purposes of investigating and clearing troubles and/or maintenance.</p> <p>b. Credit for service interruption starts when the Customer notifies the Company of the failure and ceases when the operation has been restored and an attempt has been made to notify the Customer by the Company.</p>			
Tariff Advice No. 11-619		Effective: September 18, 2009	

Issued By: Alaska Fiber Star, LLC.

By: 
 Lisa Phillips

Title: Manager, Regulatory Affairs

RCA No. 619	Original	Sheet No. 2.26	
	Canceling	Sheet No.	
Alaska Fiber Star, LLC.			
PART II – GENERAL RULES and REGULATIONS			
<p>G. <u>Payments and Charges</u> (cont.)</p> <p>6. Credit for Service Interruption (cont.)</p> <p>c. The Customer shall notify the Company of service interruptions and make reasonable attempts to ascertain that the service interruption is not cause by Customer-provided equipment or Customer-provided facilities, any act or omission of the Customer, or in wiring or equipment connected to the Customer’s terminal.</p> <p>d. Only those portions of the service interrupted will be credited.</p> <p>7. Service Interruption Measurement</p> <p>a. In the event of an interruption of service that exceeds 30 minutes, the Company shall credit the Customer’s account as follows:</p> <p style="margin-left: 40px;"> <u>Number of minutes of interruption</u> x monthly charge of the service affected 1,440 minutes in a day by the interruption x 30 days in a month </p> <p>b. A period of time less than 30 minutes shall not be credited. In no case shall the credit exceed the total charges. No adjustments will be made by accumulating periods of noncontiguous interruptions, and no other liability shall attach to the Company in consideration of such interruption to service.</p> <p>c. A credit will not be given for interruptions caused by the negligence or willful act of the Customer, or interruptions caused by failure of equipment or Services not provided by the Company.</p>			
Tariff Advice No. 11-619			Effective: September 18, 2009

Issued By: Alaska Fiber Star, LLC.

By: 
Lisa Phillips

Title: Manager, Regulatory Affairs

RCA No. 619	Original	Sheet No. 2.27	
	Canceling	Sheet No.	
Alaska Fiber Star, LLC.			
PART II – GENERAL RULES and REGULATIONS			
<p>H. <u>Termination or Denial of Service by Company</u></p> <p>The Company may, immediately and without notice to the Customer, and without liability of any nature, temporarily deny, terminate, or suspend service to any Customer in the event such Customer or its agent:</p> <ol style="list-style-type: none"> 1. Damages the Company equipment or interferes with use of the Company’s service by other Customers of the Company; 2. Unreasonably places capacity demands upon the Company’s facilities; 3. Violates any statute or provision of law, or any rule or regulation of any state or Federal regulatory agency relating to telecommunications; 4. Otherwise fails to comply with the provisions of this Tariff or applicable law; 5. Becomes insolvent, is the subject of any formal legal proceeding commenced in court involving a voluntary or involuntary petition or proceeding in bankruptcy, seeks protection or relief from creditors in a formal legal proceeding after a filing for such relief, or executes an assignment for the benefit of creditors; 6. The Customer fails to make payment required per this Tariff for any service order accepted by the Company during the term of the agreement or within 25 days of the date of the bill; or 7. The Customer breaches any other provision of this Tariff, or of any other agreement with the Company or any subsidiary or affiliate of the Company including, without limitation, any agreement for the purchase or lease by the Customer from the Company or one of its affiliates of any equipment. 			
Tariff Advice No. 11-619		Effective: September 18, 2009	

Issued By: Alaska Fiber Star, LLC.

By: 
 Lisa Phillips

Title: Manager, Regulatory Affairs

RCA No. 619	Original	Sheet No. 2.28	
	Canceling	Sheet No.	
Alaska Fiber Star, LLC.			
PART II – GENERAL RULES and REGULATIONS			
<p>I. <u>Customer Owned and Maintained Equipment</u></p> <p>1. Obligations of the Company</p> <p>a. In the event any changes contemplated by the Company can be reasonably expected to render any Customer’s terminal equipment incompatible with the Company’s communications facilities, or require modification or alteration of such terminal equipment, or otherwise materially affect its use or performance, the customer shall be given adequate notice in writing, to allow the Customer an opportunity to maintain uninterrupted service.</p> <p>b. Customer’s service may be disconnected by the Company if Customer owned and maintained equipment is causing harm to the Company’s facilities.</p> <p>c. The Company shall not be responsible for the installation, operation, or maintenance of any Customer owned equipment. The facilities of the Company are not represented as adapted to the use of Customer owned equipment and, where such Customer owned equipment is connected to the Company’s facilities, the responsibility of the Company shall be limited to the furnishing of facilities suitable for the service offered and to the maintenance and operation of such facilities in a manner proper for such services; subject to this responsibility, the Company shall not be responsible for the through transmission of signals generated by the Customer owned equipment, or for the quality of, or defects in, such transmission, or the reception of signals by the Customer owned equipment.</p>			
Tariff Advice No. 11-619		Effective: September 18, 2009	

Issued By: Alaska Fiber Star, LLC.

By: 
 Lisa Phillips

Title: Manager, Regulatory Affairs

RCA No. 619	Original	Sheet No. 2.29	
	Canceling	Sheet No.	
Alaska Fiber Star, LLC.			
PART II – GENERAL RULES and REGULATIONS			
<p>I. <u>Customer Owned and Maintained Equipment (cont.)</u></p> <p>2. Obligations of the Customer</p> <p>a. In compliance with C.F.R. Title 47, Part 68, of the FCC Rules and Regulations, Customer owned and maintained equipment may be used in conjunction with all services. The Customer shall notify the Company of each line to which said equipment is to be connected and shall notify the Company when such equipment is permanently disconnected.</p> <p>b. All Customers assume general responsibilities for failure, damage to facilities, maintenance, risk of loss, and damages for facilities owned by the Customer. All Customers assume responsibility for failure, damage to facilities, maintenance, risk of loss, and damages for the facilities which are under the control of the Customer.</p> <p>c. When facilities, equipment, and/or telecommunications systems provided by others are connected to the Company's equipment and/or facilities, the Company has no liability for the incompatibility between such systems.</p> <p>d. The Customer shall be responsible for payment of all Company charges for visits by the Company to the Customer's premises where a service difficulty or trouble results from Customer owned and maintained equipment. The amount to be charged will be computed as set forth in the Rates and Charges section of this Tariff.</p>			
Tariff Advice No. 11-619		Effective: September 18, 2009	

Issued By: Alaska Fiber Star, LLC.

By: 
 Lisa Phillips

Title: Manager, Regulatory Affairs

RCA No. 619	Original Canceling	Sheet No. 2.30 Sheet No.	
Alaska Fiber Star, LLC.			
PART II – GENERAL RULES and REGULATIONS			
<p>I. <u>Customer Owned and Maintained Equipment (cont.)</u></p> <p>3. Violation of Tariffs</p> <p>Except as set forth in C.F.R. Title 47, Part 68, of the FCC Rules and Regulations, where any Customer owned equipment is used in violations of any of the provisions of this Tariff, the Company will take such immediate action as is necessary for the protection of its facilities and network, and will promptly notify the Customer of the violation.</p> <p>The Customer shall discontinue use of the equipment or correct the violation and shall confirm in writing to the Company within ten (10) days following the receipt of written notice from the Company, that such use has ceased or that the violation has been corrected. Failure of the Customer to discontinue such use or to correct the violation and to give the required written confirmation to the Company within the time stated, shall result in termination of the Customer’s service until such time as the Customer complies with the provisions of this Tariff.</p>			
Tariff Advice No. 11-619		Effective: September 18, 2009	

Issued By: Alaska Fiber Star, LLC.

By: 
 Lisa Phillips

Title: Manager, Regulatory Affairs

RCA No. 619	Original Canceling	Sheet No. 2.31 Sheet No.	
Alaska Fiber Star, LLC.			
PART II – GENERAL RULES and REGULATIONS			
<p>I. <u>Customer Owned and Maintained Equipment (cont.)</u></p> <p>4. Company Liability</p> <p>The use of Customer owned equipment for the transmission and/or reception of data or speech signals is permitted only on the condition that the liability of the Company for damages arising out of mistakes, omissions, interruptions, delays, or errors or defects in transmission, or failure or defects in the equipment occurring in the course of furnishing service or other facilities and not caused by the negligence of the Customer, or of the Company in failing to maintain proper standards of maintenance and operation and to exercise reasonable supervision, shall in no event exceed an amount equivalent to the proportionate charge to the Customer for the period of service during which such mistakes, omissions, interruptions, delay, or errors or defects in transmission, or failure or defects in the equipment occur.</p> <p>The Customer indemnifies and holds the Company harmless against claims of libel, slander, or infringement of copyright arising from material transmitted over its facilities, against claims for infringement of patents arising from combining with, or using in connections with, facilities of the Company, apparatus and systems of the Customers, and against all other claims arising out of any act or omission of the Customer in connection with the facilities provided by the Company.</p>			
Tariff Advice No. 11-619		Effective: September 18, 2009	

Issued By: Alaska Fiber Star, LLC.

By: 
 Lisa Phillips

Title: Manager, Regulatory Affairs

RCA No. 619	Original	Sheet No. 2.32	
	Canceling	Sheet No.	
Alaska Fiber Star, LLC.			
PART II – GENERAL RULES and REGULATIONS			
J.	<u>Special Services</u>		
1.	General		
	<p>For the purpose of this Tariff, a Special Services is deemed to be any service offering requested by the Customer and provided by the Company for which there is no prescribed rate in this Tariff. Special services charges will be developed on an Individual Case Bases (ICB) and may be established by contract between the Company and the Customer. Such contract or ICB rates will be filed with the Commission for its approval, if required by applicable rules and regulations.</p>		
2.	When Applicable		
	Special services rates apply in the following circumstances:		
a.	If, at the request of the Customer, the Company obtains facilities not normally used by the Company to provide Tariffed services to its Customer;		
b.	If, at the request of the Customer, the Company provides technical assistance not normally required to provide the services in this Tariff.		
c.	<p>If the Customer makes or requests material changes in circuit engineering, equipment specifications, service parameters, premises locations, or otherwise materially modifies any provision of the application for service, additional charges may be levied as follows:</p>		
1)	Where, prior to the Customer requested change, the Company incurs any expense in installing or preparing to install the service that it otherwise would not have incurred, those expenses may be charged to the Customer.		
Tariff Advice No. 11-619			Effective: September 18, 2009

Issued By: Alaska Fiber Star, LLC.

By: 
 Lisa Phillips

Title: Manager, Regulatory Affairs

RCA No. 619	Original Canceling	Sheet No. 2.33 Sheet No.	
Alaska Fiber Star, LLC.			
PART II – GENERAL RULES and REGULATIONS			
<p>J. <u>Special Services</u> (cont.)</p> <p> 2. When Applicable</p> <p> c. (cont.)</p> <p> 2) The costs of modifying the implementation of service for the new Customer request will be determined on a case-by-case basis, factoring in the extent to which previous elements are still usable.</p> <p>K. <u>Special Pricing Arrangements</u></p> <p> Customized service packages and competitive pricing arrangements at negotiated rates may be furnished on an ICB in response to requests by Customer for proposals or for competitive bids. Special pricing arrangements offered will be provided to the Customer pursuant to special contract. Unless otherwise specified, the regulations for such arrangements are in addition to the applicable regulation and prices in other sections of the Tariff. Special rates or charges will be made available to similarly situated Customers on a nondiscriminatory basis. Special contracts containing special pricing arrangements which vary from the rates, terms, and conditions in this Tariff shall be filed with the Regulatory Commission of Alaska for approval, if required by applicable rule or regulation.</p>			
Tariff Advice No. 11-619		Effective: September 18, 2009	

Issued By: Alaska Fiber Star, LLC.

By: 
 Lisa Phillips

Title: Manager, Regulatory Affairs

RCA No. 619	Original Canceling	Sheet No. 2.34 Sheet No.	
Alaska Fiber Star, LLC.			
PART II – GENERAL RULES and REGULATIONS			
<p>L. <u>Special Construction</u></p> <p>1. General</p> <p> All rates and charges quoted in this Tariff provide for the furnishing of a service when suitable facilities are available or where the construction of the necessary facilities does not involve unusual costs. When the revenue to be derived from the service does not warrant the Company assuming the unusual costs of providing the necessary construction, the Customer may be required to pay all or a portion of such costs and to contract for the service for a sufficient period to warrant the construction, depending upon the circumstances in each case. The Company's charges for such special construction shall follow the same guidelines for establishing charges for special services. The Company shall have no obligation to construct facilities necessary to provide services.</p> <p>2. Jointly Placed Facilities</p> <p> In the event that multiple service providers wish to place their own facilities in conjunction with AFS' construction of new facilities, the cost of the new construction will be shared equally among the participating service providers. The cost of the new construction will include the items identified below, except that the costs of the actual materials will be borne separately by each of the providers.</p>			
Tariff Advice No. 11-619		Effective: September 18, 2009	

Issued By: Alaska Fiber Star, LLC.

By: 
 Lisa Phillips

Title: Manager, Regulatory Affairs

RCA No. 619	Original Canceling	Sheet No. 2.35 Sheet No.	
Alaska Fiber Star, LLC.			
PART II – GENERAL RULES and REGULATIONS			
<p>L. <u>Special Construction</u> (cont.)</p> <p>3. Basis for Cost Computation</p> <p> The costs referred to above may include one or more of the following items to the extent they are applicable:</p> <p> a. cost installed of the facilities to be provided, including estimated costs for the rearrangement of existing facilities. Cost installed includes:</p> <p> 1) equipment and materials provided or used,</p> <p> 2) engineering, construction labor, supervision, project management , and overhead</p> <p> 3) transportation, and</p> <p> 4) rights of way;</p> <p> b. cost of maintenance;</p> <p> c. depreciation on the estimated cost installed of any facilities provided, based on the anticipated useful service life of the facilities with an appropriate allowance for the estimate net salvage;</p> <p> d. administration, taxes, and uncollectible revenue on the basis of reasonable average costs for these items;</p> <p> e. license preparation, processing, and related fees;</p> <p> f. tariff preparation, processing, and related fees;</p> <p> g. any other identifiable costs related to the facilities provided; and</p> <p> h. an amount for return and contingencies.</p>			
Tariff Advice No. 11-619		Effective: September 18, 2009	

Issued By: Alaska Fiber Star, LLC.

By: 
 Lisa Phillips

Title: Manager, Regulatory Affairs

RCA No. 619	Original Canceling	Sheet No. 2.36 Sheet No.	
Alaska Fiber Star, LLC.			
PART II – GENERAL RULES and REGULATIONS			
<p>M. <u>Inspection, Testing, and Adjustments</u></p> <ol style="list-style-type: none"> 1. The Company may, upon reasonable notice, make such tests and inspections as may be necessary to investigate the installation, operation, or maintenance of the Customer’s or the Company’s equipment or connecting facilities. The Company may interrupt service at any time, without penalty or liability to itself, where necessary to prevent improper use of service, equipment, facilities, or connections. 2. Upon reasonable notice, the facilities and equipment provided by the Company shall be made available to the Company for such tests and adjustments as may be necessary for its maintenance in a condition satisfactory to the Company. No interruption allowance will be granted for the time during which such tests and adjustments are made, unless such interruption exceeds 24 hours in length. 			
Tariff Advice No. 11-619		Effective: September 18, 2009	

Issued By: Alaska Fiber Star, LLC.

By: 
 Lisa Phillips

Title: Manager, Regulatory Affairs

RCA No. 619	Original Canceling	Sheet No. 2.37 Sheet No.	
Alaska Fiber Star, LLC.			
PART II – GENERAL RULES and REGULATIONS			
<p>N. <u>Confidential Information</u></p> <p>Either the Company or the Customer may, from time to time, give written notice to the other specifically identifying information that is to be kept confidential. When either the Company or the Customer receives such notice, it will not produce or disclose the confidential information to third parties unless ordered to do so by a court, regulatory agency, or other official body and then only upon written notice to the other Party. No information shall be considered confidential if:</p> <ol style="list-style-type: none"> 1. It is already in the public domain; 2. It has been revealed to others by the Party to whom the information belongs without being designated as confidential; 3. It became available to the public by publications or otherwise after disclosure to the recipient; or 4. It was already in the possession of the recipient at the time of disclosure to the recipient. <p>Notwithstanding any other provisions in this section, the Company and the Customer agree that the Company may disclose information which is necessary to obtain financing or as required by law or court order. The provision of this sections shall survive the expiration of the service(s) for whatever reason.</p>			
Tariff Advice No. 11-619		Effective: September 18, 2009	

Issued By: Alaska Fiber Star, LLC.

By: 
 Lisa Phillips

Title: Manager, Regulatory Affairs

RCA No. 619	Original Canceling	Sheet No. 2.38 Sheet No.	
Alaska Fiber Star, LLC.			
PART II – GENERAL RULES and REGULATIONS			
<p>O. <u>Assignment and Binding Effect</u></p> <p>The Customer may not assign, transfer, or otherwise dispose of any of its rights or obligations contained in this Tariff in any manner whatsoever, including but not limited to a merger or sale of substantially all of the assets of the Customer, without the prior written consent of the Company, which consent shall be in the Company’s sole discretion. Notwithstanding this, an assignment by operation of law is deemed an assignment. Subject only to any necessary approvals of the Commission, the Company may assign its rights or obligations without the prior consent of the Customer to:</p> <ol style="list-style-type: none"> 1. Any party in connection with any financing or refinancing; 2. Any successor to the Company that results from a merger, consolidation, or sale of substantially all of the Company’s assets; or 3. Any parents, subsidiaries, and any other entities that are owned or controlled by, or under common ownership and control with, the Company. <p>The obligations of the Company and the Customer hereunder shall be binding on and inure to the benefit of all of the Company’s and the Customer’s successors and assigns.</p>			
Tariff Advice No. 11-619		Effective: September 18, 2009	

Issued By: Alaska Fiber Star, LLC.

By: 
 Lisa Phillips

Title: Manager, Regulatory Affairs

RCA No. 619	Original	Sheet No. 3.1	
	Canceling	Sheet No.	
Alaska Fiber Star, LLC.			
PART III – SPECIAL ACCESS SERVICES			
<p>A. <u>General</u></p> <ol style="list-style-type: none"> 1. Special Access Service provides a transmission path for connecting two or more Customer-designated premises either directly or through a Company hub or hubs where bridging or multiplexing functions are performed. Special Access Services may be used to provide connectivity from a Customer-designated premises to a DSL Access Multiplexer (DSLAM) or to the Public Packet Data Network. 2. The connections provided by Special Access Service are digital. 3. Equipment for use in connection with Special Access Services is furnished either by the Company or by the subscriber. Equipment furnished by the Company shall not be used for any purpose other than that for which it is provided. Equipment furnished by the subscriber shall also be so constructed, maintained, and operated as to comply with C.F.R. Title 47, Part 68, of the FCC Rules and Regulations. 4. The normal time interval for service (from service order to cutover) is dependent upon the availability of equipment and seasonal construction. A list of estimated time intervals can be provided by the Company. <ol style="list-style-type: none"> a. Availability of Equipment <p>The interval will be 30 days when equipment is available from stock, 60 days when equipment must be ordered.</p> b. Seasonal Construction <p>Any service order from May 1 through October 15 will be classified as normal construction activity and thus will comply with the 30-day time interval. Any construction required from October 16 through April 30 may require special construction and a 60-day time interval.</p> 			
Tariff Advice No. 11-619		Effective: September 18, 2009	

Issued By: Alaska Fiber Star, LLC.

By: 
 Lisa Phillips

Title: Manager, Regulatory Affairs

RCA No. 619	Original Canceling	Sheet No. 3.2 Sheet No.	
Alaska Fiber Star, LLC.			
PART III – SPECIAL ACCESS SERVICES			
<p>A. <u>General</u> (cont.)</p> <p>5. Minimum Length of Service for Special Access Services</p> <p>The minimum length of service for this offering is 120 days. Customers will be charged a minimum of 120 days of service even if the channel is disconnected prior to that time.</p> <p>B. <u>Channel Types</u></p> <p>Special Access Services are provided through the following channel type: High Capacity – a channel for the transmission of isochronous serial digital data at rates of 1.544 Mbps.</p> <p>For purposes of ordering channels, each has been identified as a type of Special Access Service. However, such identification is not intended to limit a Customer’s use of the channel, nor to imply that the channel is limited to a particular use.</p> <p>Customers can order a basic channel and select available transmission parameters and channel interfaces that they desire in order to meet specific communications requirements.</p> <p>The Customer also has the option of ordering Special Access channels to Company hubs for multiplexing to individual channels of a lower capacity or bandwidth. Descriptions of the types of multiplexing available at the hubs, as well as the number of individual channels which may be derived from each type of facility are set forth in subsection H, following. Additionally, the Customer may specify optional features for the individual channels derived from the facility to further tailor the channel to meet specific communications requirements. Descriptions of the option features and functions available are set forth in subsections I and J, following.</p>			
Tariff Advice No. 11-619		Effective: September 18, 2009	

Issued By: Alaska Fiber Star, LLC.

By: 
 Lisa Phillips

Title: Manager, Regulatory Affairs

RCA No. 619	Original Canceling	Sheet No. 3.3 Sheet No.	
Alaska Fiber Star, LLC.			
PART III – SPECIAL ACCESS SERVICES			
<p>C. <u>Service Descriptions</u></p> <p>Each service consists of a basic channel to which technical specifications, channel interface(s), and, when desired, optional features and functions are added to construct the service desired by the Customer. If the Company determines that the requested parameter specifications are not compatible, the Customer will be advised and given the opportunity to change the order.</p> <ol style="list-style-type: none"> 1. Channel interfaces at each point of termination on a two-point service may be symmetrical or asymmetrical. On a multipoint service they may also be symmetrical or asymmetrical. Asymmetrical service is dependent on equipment capability (both customer and network) and is limited to services in this Tariff. 2. Only certain channel interfaces combinations are available with certain technical specifications. When a customized channel is requested, all channel interface combinations available with the specified type of service are available with the customized channel. 3. The optional features and functions available with each type of Special Access Service are described in subsections I and J, following. 4. All services will conform to the transmission specifications standards contained in this Tariff or in the following Technical References for each category of service: <ul style="list-style-type: none"> • High Capacity ANSI T1.102 ANSI T1.107 			
Tariff Advice No. 11-619		Effective: September 18, 2009	

Issued By: Alaska Fiber Star, LLC.

By: 
Lisa Phillips

Title: Manager, Regulatory Affairs

RCA No. 619

Original

Sheet No. 3.4

Canceling

Sheet No.

Alaska Fiber Star, LLC.

PART III – SPECIAL ACCESS SERVICES

D. Service Configurations

There are three types of service configurations over which Special Access Services are provided: two-point services, multipoint service, and synchronous optical channel service.

1. Two-Point Service

A two-point service connects two Customer-designated premises, either on a directly connected basis or through a hub, where multiplexing functions are performed.

Applicable rate elements are:

- Channel Terminations
- Channel Mileage (as applicable)
- Optional Features and Functions (when applicable)

The following diagram depicts two-point service connecting two Customer Designated Premises (CDPs) through two Customer Serving Wire Centers (C-SWCs):

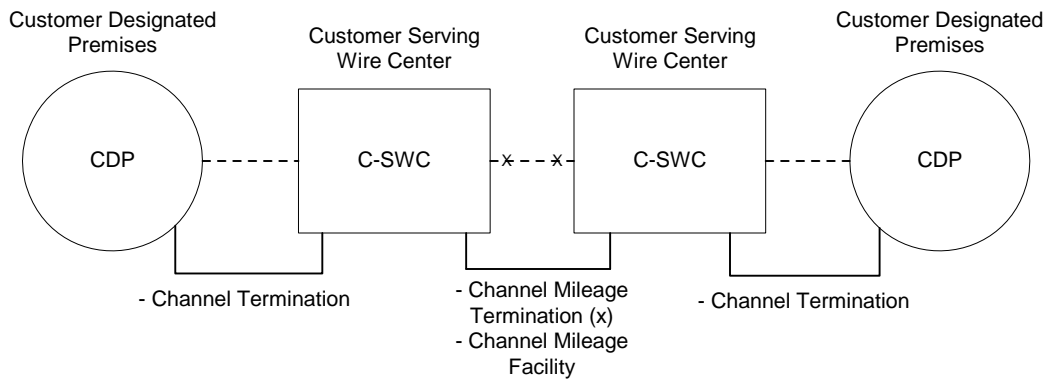

Tariff Advice No. 11-619

Effective: September 18, 2009

Issued By: Alaska Fiber Star, LLC.

By: *Lisa Phillips*
Lisa Phillips

Title: Manager, Regulatory Affairs

RCA No. 619	Original Canceling	Sheet No. 3.5 Sheet No.	
Alaska Fiber Star, LLC.			
PART III – SPECIAL ACCESS SERVICES			
<p>D. <u>Service Configurations</u> (cont.)</p> <p>2. Multipoint Service</p> <p>Multipoint service connects three or more CDPs through one or more Company hubs. Only certain types of Special Access Service are provided as multipoint service. These are so designated in the description for the appropriate channel.</p> <p>Multipoint service utilizing a customized technical specifications package will be provided when technically possible. If the Company determines that the requested characteristics for a multipoint service are not compatible, the Customer will be advised and given the opportunity to change the order.</p> <p>Applicable rate elements are:</p> <ul style="list-style-type: none"> • Channel Terminations (one per CDP) • Channel Mileage (as applicable between the C-SWC for each CDP and the hub and between hubs) • Bridging • Additional Optional Features and Functions (when applicable) 			
Tariff Advice No. 11-619		Effective: September 18, 2009	

Issued By: Alaska Fiber Star, LLC.

By: 
 Lisa Phillips

Title: Manager, Regulatory Affairs

RCA No. 619

Original

Sheet No. 3.6

Canceling

Sheet No.

Alaska Fiber Star, LLC.

PART III – SPECIAL ACCESS SERVICES

D. Service Configurations (cont.)

2. Multipoint Service (cont.)

The following diagram depicts multipoint service connecting four Customer Designated Premises (CDPs) via two Customer-specified bridging hubs:

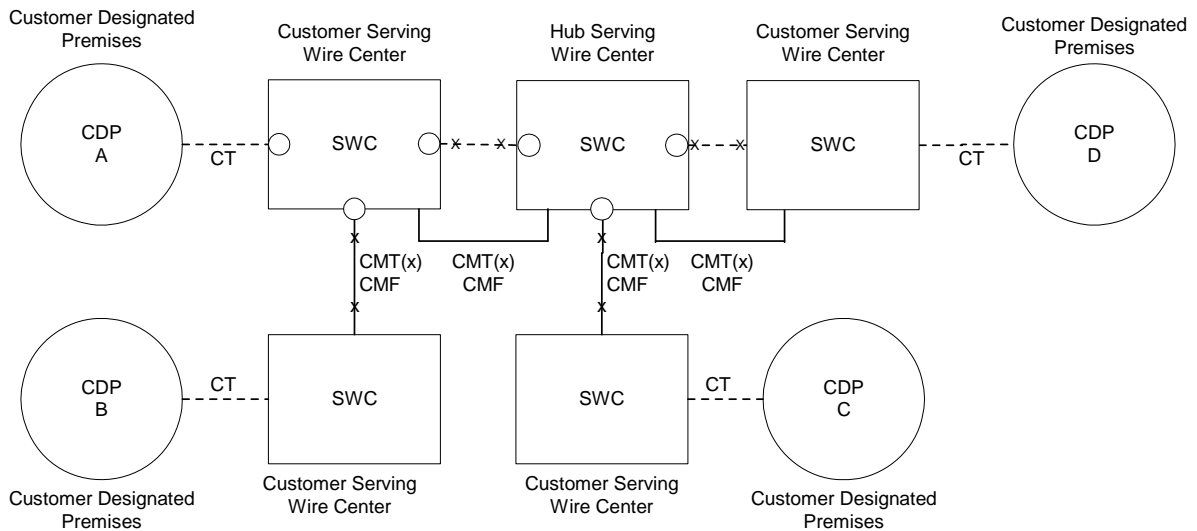

CT Channel Termination
 CMT Channel Mileage Termination
 CMF Channel Mileage Facility
 O Bridging Port

Tariff Advice No. 11-619

Effective: September 18, 2009

Issued By: Alaska Fiber Star, LLC.

By: *Lisa Phillips*
 Lisa Phillips

Title: Manager, Regulatory Affairs

RCA No. 619	Original	Sheet No. 3.7	
	Canceling	Sheet No.	
Alaska Fiber Star, LLC.			
PART III – SPECIAL ACCESS SERVICES			
<p>D. <u>Service Configurations</u> (cont.)</p> <p>2. Multipoint Service (cont.)</p> <p>Applicable rate elements are:</p> <ul style="list-style-type: none"> • Channel Terminations (4 applicable) • Channel Mileage (2 Channel Mileage Terminations per Channel Mileage Facility section for a total of 8 plus 4 sections, Channel Mileage Facility per mile) • Bridging Optional Feature (6 applicable; i.e., each bridge port) <p>E. <u>Special Facilities Routing</u></p> <p>A Customer may request that the facilities used to provide Special Access Service be specially routed. Special Facilities Routing will be provided on an Individual Case Basis.</p> <p>F. <u>Design Layout Report</u></p> <p>At the request of the Customer, the Company will provide to the Customer the make-up of the facilities and services provided under this Tariff as Special Access Service to aid the Customer in designing its overall service. This information will be provided in the form of a Design Layout Report. The Design Layout Report will be provided to the Customer at no charge, and will be reissued or updated whenever these facilities are materially changed.</p>			
Tariff Advice No. 11-619		Effective: September 18, 2009	

Issued By: Alaska Fiber Star, LLC.

By: 
 Lisa Phillips

Title: Manager, Regulatory Affairs

RCA No. 619	Original Canceling	Sheet No. 3.8 Sheet No.	
Alaska Fiber Star, LLC.			
PART III – SPECIAL ACCESS SERVICES			
<p>G. <u>Rate Regulations</u></p> <p>This section contains the specific regulations governing the rates and charges that apply for Special Access.</p> <p>1. Rate Types</p> <p>a. Monthly Rates</p> <p>Monthly rates are recurring rates that apply each month or fraction thereof that a Special Access Service is provided. For billing purposes, each month is considered to have 30 days.</p> <p>b. Nonrecurring Charges</p> <p>Nonrecurring charge are one-time charges that apply for specific work activity (i.e., installation or change to an existing service). The types of nonrecurring charges that apply for Special Access Service are: installation of service, installation of optional features and functions, and service rearrangements.</p> <p>2. Monthly Rate Categories</p> <p>There are three basic rate categories which apply to Special Access Service:</p> <ul style="list-style-type: none"> • Channel Terminations • Channel Mileage (consisting of Channel Mileage Termination and Channel Mileage Facility charges) • Optional Features and Functions 			
Tariff Advice No. 11-619		Effective: September 18, 2009	

Issued By: Alaska Fiber Star, LLC.

By: 
 Lisa Phillips

Title: Manager, Regulatory Affairs

RCA No. 619	Original Canceling	Sheet No. 3.9 Sheet No.	
Alaska Fiber Star, LLC.			
PART III – SPECIAL ACCESS SERVICES			
<p>G. <u>Rate Regulations</u> (cont.)</p> <p> 2. Monthly Rate Categories (cont.)</p> <p> a. Channel Termination</p> <p> The Channel Termination rate category recovers the costs associated with the communications path between a Customer Designated Premises (CDP) and the serving wire center of that premises. Included as part of the Channel Termination is a standard channel interface arrangement which defines the technical characteristics associated with the type of facilities to which the access service is to be connected and the type of signaling capability, if any. The signaling capability is provided as an optional feature as set forth in (c), following.</p> <p> One Channel Termination charge applies per CDP at which the channel is terminated. This charge will apply even if the CDP and the serving wire center are collocated in a Company building.</p> <p> For a 1.544 Mbps High Capacity Service connecting a CDP to a Public Packet Data Network as described in Section I, following, there will be a charge for only one Channel Termination.</p>			
Tariff Advice No. 11-619		Effective: September 18, 2009	

Issued By: Alaska Fiber Star, LLC.

By: 
 Lisa Phillips

Title: Manager, Regulatory Affairs

RCA No. 619	Original Canceling	Sheet No. 3.10 Sheet No.	
Alaska Fiber Star, LLC.			
PART III – SPECIAL ACCESS SERVICES			
<p>G. <u>Rate Regulations</u> (cont.)</p> <p>2. Monthly Rate Categories (cont.)</p> <p>b. Channel Mileage</p> <p>The Channel Mileage rate category recovers the costs associated with the transmission facilities between the serving wire centers associated with two CDPs, including facilities between or to immediate wire centers, Company Hubs, and Add/Drop Multiplexing (ADM) wire centers. The transmission facilities can include high capacity channels, optical carrier channels, or a combination depending on the service configuration. The Channel Mileage includes Channel Mileage Facility, which is the transmission path, and Channel Mileage Termination, which is the equipment used to terminate the transmission path.</p> <p>1) Channel Mileage Facility</p> <p>The Channel Mileage Facility rate recovers the per mile cost for the transmission path which extends between the Company serving wire centers and/or hub(s) or between the Company serving wire center and another wire center equipped for Frame Relay Access Service.</p>			
Tariff Advice No. 11-619		Effective: September 18, 2009	

Issued By: Alaska Fiber Star, LLC.

By: 
 Lisa Phillips

Title: Manager, Regulatory Affairs

RCA No. 619	Original Canceling	Sheet No. 3.11 Sheet No.	
Alaska Fiber Star, LLC.			
PART III – SPECIAL ACCESS SERVICES			
<p>G. <u>Rate Regulations</u> (cont.)</p> <p>2. Monthly Rate Categories (cont.)</p> <p>b. Channel Mileage (cont.)</p> <p>2) Channel Mileage Termination</p> <p>The Channel Mileage Termination rate recovers the cost for end office equipment associated with terminating the facility (i.e., basic circuit equipment and terminations at serving wire center and hubs). The Channel Mileage Termination rate will apply at the serving wire center(s) for each CDP and Company hub where the channel is terminated. If the Channel Mileage is between Company bridging hubs, the Channel Mileage Termination rate will apply per Company designated hub. If the Channel Mileage is between the serving wire center for a CDP and another wire center equipped for Frame Relay Access Service, the Channel Mileage Termination rate will apply only at the serving wire center for the CDP.</p> <p>The Channel Mileage Termination and Channel Mileage Facility rates do not apply when both CDPs use the same serving wire center.</p>			
Tariff Advice No. 11-619		Effective: September 18, 2009	

Issued By: Alaska Fiber Star, LLC.

By: 
 Lisa Phillips

Title: Manager, Regulatory Affairs

RCA No. 619	Original Canceling	Sheet No. 3.12 Sheet No.	
Alaska Fiber Star, LLC.			
PART III – SPECIAL ACCESS SERVICES			
<p>G. <u>Rate Regulations</u> (cont.)</p> <p>2. Monthly Rate Categories (cont.)</p> <p>c. Optional Features and Functions</p> <p>The Optional Features and Functions rate category recovers the costs associated with options features and functions which may be added to a Special Access Service to improve its quality or utility to met specific communications requirements. These are not necessarily identifiable with specific equipment, but rather represent the end result in terms of performance characteristics that may be obtained.</p> <p>These characteristics may be obtained by using various combinations on equipment. Although the equipment necessary to perform a specified function may be installed at various locations along the path of service, they will be charged for as a single rate element.</p> <p>Examples of Optional Features and Functions that are available include, but are not limited to, the following:</p> <ul style="list-style-type: none"> • Signaling Capability • Hubbing Functions • Conditioning • Transfer Arrangements <p>A hub is a Company-designated serving wire center at which bridging or multiplexing functions are performed. The bridging functions performed are to connect three or more CDPs in a multipoint arrangement.</p>			
Tariff Advice No. 11-619		Effective: September 18, 2009	

Issued By: Alaska Fiber Star, LLC.

By: 
 Lisa Phillips

Title: Manager, Regulatory Affairs

RCA No. 619	Original Canceling	Sheet No. 3.13 Sheet No.	
Alaska Fiber Star, LLC.			
PART III – SPECIAL ACCESS SERVICES			
<p>G. <u>Rate Regulations</u> (cont.)</p> <p>3. Nonrecurring Rate Categories</p> <p>a. Installation of Service</p> <p>Nonrecurring charge apply to each service installed. The nonrecurring charges for the installation of service are set for each channel type as a nonrecurring charge for the Channel Termination. Nonrecurring installation charges are as set forth in the Rates and Charges section of this Tariff.</p> <p>b. Installation of Optional Features and Functions</p> <p>When optional features and functions are installed coincident with the initial installation of service, no separate nonrecurring charge is applicable. When optional features are functions are installed or changed subsequent to the installation of service, applicable nonrecurring charges will apply.</p> <p>4. Mileage Determination</p> <p>The mileage to be used to determine the monthly rate for the Channel Mileage Facility is calculated on the airline distance between the locations involved, i.e.,</p> <ul style="list-style-type: none"> • the serving wire centers associated with two CDPs, • a serving wire center associated with a CDP and a Company hub, • a serving wire center associated with a CDP and a wire center equipped for Frame Relay Access Service, • a serving wire center associated with a CDP and a DSL Access Service Connection Point, • two Company hubs, • a serving wire center associated with a CDP and a wire center equipped for Add/Drop Multiplexing, • two wire centers equipped for Add/Drop Multiplexing. 			
Tariff Advice No. 11-619		Effective: September 18, 2009	

Issued By: Alaska Fiber Star, LLC.

By: 
 Lisa Phillips

Title: Manager, Regulatory Affairs

RCA No. 619	Original Canceling	Sheet No. 3.14 Sheet No.	
Alaska Fiber Star, LLC.			
PART III – SPECIAL ACCESS SERVICES			
<p>G. <u>Rate Regulations</u> (cont.)</p> <p>4. Mileage Determination (cont.)</p> <p>The serving wire center associated with a CDP is the wire center at which the Customer accesses the services under this Tariff.</p> <p>Mileage charges are shown with each channel type.</p> <p>When hubs are involved, mileage is computer and rates applied separately for each section of the Channel Mileage, i.e.,</p> <ul style="list-style-type: none"> • CDPs serving wire center to hub, • hub to hub, and/or • hub to CDPs serving wire center. <p>However, when any service is routed through a hub for purposes other than Customer specified bridging or multiplexing (e.g., the Company chooses to so route for test access purposes), rates will be applied only to the distance calculated between the serving wire centers associated with the CDP.</p> <p>See the service configurations example for multipoint service as set forth in Section D, preceding.</p>			
Tariff Advice No. 11-619		Effective: September 18, 2009	

Issued By: Alaska Fiber Star, LLC.

By: 
 Lisa Phillips

Title: Manager, Regulatory Affairs

RCA No. 619	Original	Sheet No. 3.15					
	Canceling	Sheet No.					
Alaska Fiber Star, LLC.							
PART III – SPECIAL ACCESS SERVICES							
<p>H. <u>High Capacity Channel Service</u></p> <p>1. Basic Channel Description – High Capacity Channel</p> <p>A High Capacity channel is a channel for the transmission of 1.544 Mbps, isochronous serial data. The actual bit rate is a function of the channel interface selected by the Customer. High Capacity channels are provided between CDPs or between a CDP and a Company hub or hubs. In addition, 1.544 Mbps High Capacity Service channels may be provided between a CDP and Company designated DSL Access Service Connection Point. The Customer may provide the Network Channel Terminating Equipment associated with the High Capacity channel at the Customer’s premises.</p> <p>2. Technical Specifications Packages and Network Channel Interfaces</p> <p>The following Network Channel Interfaces (NCIs) define the bit rates that are available for a High Capacity channel:</p> <table style="margin-left: auto; margin-right: auto;"> <thead> <tr> <th style="text-align: center;"><u>NCI</u></th> <th style="text-align: center;"><u>Bit Rate</u></th> </tr> </thead> <tbody> <tr> <td style="text-align: center;">DS-15</td> <td style="text-align: center;">1.544 Mbps (DS1)</td> </tr> </tbody> </table>				<u>NCI</u>	<u>Bit Rate</u>	DS-15	1.544 Mbps (DS1)
<u>NCI</u>	<u>Bit Rate</u>						
DS-15	1.544 Mbps (DS1)						
Tariff Advice No. 11-619		Effective: September 18, 2009					

Issued By: Alaska Fiber Star, LLC.

By: 
 Lisa Phillips

Title: Manager, Regulatory Affairs

RCA No. 619	Original Canceling	Sheet No. 3.16 Sheet No.	
Alaska Fiber Star, LLC.			
PART III – SPECIAL ACCESS SERVICES			
<p>H. <u>High Capacity Channel Service</u> (cont.)</p> <p>3. Optional Features and Functions</p> <p>a. Automatic Protection Switching</p> <p>The Automatic Protection Switching provides protection on a 1xN basis against failure of the facilities between a CDP and the wire center serving that premises. Protection is furnished through the use of a switching arrangement that automatically switches to a spare channel line when a working line fails. The spare channel is not included as a part of the option. This option required compatible equipment at both the serving wire center and both CDPs. The Customer is responsible for providing the compatible equipment at its designated premises.</p> <p>b. DSL Access Service Connection</p> <p>The DSL Access Service Connection function provides for the interconnection of a 1.544 Mbps High Capacity Service as described in Technical Reference ANSI T1.413-1998.</p> <p>Rates and charges for the DSL Access Service Connection function are set forth in the Rates and Charges section of this Tariff. This function applies to each 1.544 Mbps High Capacity Service terminated at a DSL Access Service Connection Point.</p>			
Tariff Advice No. 11-619		Effective: September 18, 2009	

Issued By: Alaska Fiber Star, LLC.

By: 
 Lisa Phillips

Title: Manager, Regulatory Affairs

RCA No. 619 Original Canceling	Sheet No. 3.17 Sheet No.	
Alaska Fiber Star, LLC.		
PART III – SPECIAL ACCESS SERVICES		
<p>I. <u>Continuous Property Service</u></p> <p>The Continuous Property Service rate category recovers the costs associated with Company equipment and facilities that are used to provide a communications path between Customer Owner and Maintained Equipment at two different locations on the Customer Designated Premises within the same building or on the same continuous property. The continuous property service will be determined on an Individual Case Basis.</p> <p>J. <u>Individual Case Basis Filings</u></p> <p>Certain services set forth in this Special Access Services section are provided on an Individual Case Basis (ICB).</p>		
Tariff Advice No. 11-619		Effective: September 18, 2009

Issued By: Alaska Fiber Star, LLC.

By: 
Lisa Phillips

Title: Manager, Regulatory Affairs

RCA No. 619	Original Canceling	Sheet No. 4.1 Sheet No.	
Alaska Fiber Star, LLC.			
PART IV – FRAME RELAY SERVICE			
<p>A. <u>General</u></p> <p>Frame Relay Service (FRS) is a “fast packet” network service that permits the transmission of data at speeds of 1.544 and 44.736 Mbps using Permanent Virtual Circuits (PVCs).</p> <p>PVCs are logical circuits that define a specific path for data sent by the customer to another location including a DSL Access Service Connection Point as described in Part III – Special Access Services, section I. These circuits are virtual because they are established in software tables and do not tie up capacity when not in use. This also allows multiple PVCs to be defined over a single access line, thereby providing a single access line the capability to transmit data to and from multiple destinations.</p> <p>In the operation of FRS, Customer Premises Equipment (CPE) such as routers encapsulated data into variable length frames. These frames contain information identifying which PVC in the network should be used to forward the frame to the proper destination. The CPE then sends the frame into the Frame Relay Network. The Frame Relay switch reads identifying information and routes the frame to the proper destination, based on a pre-established PVC.</p> <p>The statistical multiplexing Frame Relay switches are able to provide shared network resources to end users of this section.</p> <p>The regulations and rates specified herein are in addition to the applicable regulations and rates specified in other sections of this Tariff.</p>			
Tariff Advice No. 11-619		Effective: September 18, 2009	

Issued By: Alaska Fiber Star, LLC.

By: 
 Lisa Phillips

Title: Manager, Regulatory Affairs

RCA No. 619	Original Canceling	Sheet No. 4.2 Sheet No.	
Alaska Fiber Star, LLC.			
PART IV – FRAME RELAY SERVICE			
<p>B. <u>Service Elements</u></p> <ol style="list-style-type: none"> 1. Frame Relay Data Link <p>A nonrecurring charge and monthly rate, both based on the data speed (e.g., 1.544 Mbps), apply to each physical connection to the network supporting Frame Relay Service (FRS). Each Data Link represents one physical connection.</p> 2. Frame Relay Port <p>A nonrecurring charge and monthly rate, based on the data speed of the port connection (e.g., 1.544 Mbps), apply per port for each Frame Relay Data Link to the network supporting FRS. Each port can have multiple PVCs.</p> 3. Frame Relay PVC (FR-PVC) <ol style="list-style-type: none"> a. A nonrecurring charge and a monthly rate apply for each PVC. A monthly rate is based on the data speed of the PVCs assigned to the port. b. A nonrecurring charge applies for each subsequent order of PVC(s) to be added or PVC assignment(s) changed on an existing FRS. 			
Tariff Advice No. 11-619		Effective: September 18, 2009	

Issued By: Alaska Fiber Star, LLC.

By: 
 Lisa Phillips

Title: Manager, Regulatory Affairs

RCA No. 619	Original	Sheet No. 4.3	
	Canceling	Sheet No.	
Alaska Fiber Star, LLC.			
PART IV – FRAME RELAY SERVICE			
<p>C. <u>Regulations</u></p> <ol style="list-style-type: none"> 1. Frame Relay is a transport service that facilitates the exchange of variable length information units (frames) between end user connections by way of PVCs. Each frame is passed to the Frame Relay Network with an address that specifies the virtual connection. 2. Variable frame length capability is useful in communications between asynchronous Local Area Networks (LANs) and for transport of synchronous data traffic. Frame Relay is capable of handling the requirements of burst data sources because of the ability of the service to allocate additional bandwidth when not in use by other sources. 3. Frame Relay Service is provided to the Customer in the form of a Frame Relay Data Link, Frame Relay Port, and the Permanent Virtual Circuits. The Frame Relay Data Link forms the local access component which provides the Customer access to the Customer’s serving central office and a primary address associated specifically with that Customer. The Frame Relay Data Link is provided only for use with Frame Relay Service. 4. The actual throughput of aggregated PVC bandwidth in use at the same time on the same port cannot exceed the port speed. 5. Since all PVCs are not typically in use at the same time, the Customer may elect to have the total bandwidth of all PVCs associated with one Frame Relay Port to exceed the bandwidth of that Frame Relay Port. The relationship is referred to as “oversubscription” and when this occurs, there can be no guarantee that the bandwidth defined for that PVC will be available at any point in time. 6. No PVC can have a greater bandwidth than that of the associated Frame Relay Port. 			
Tariff Advice No. 11-619			Effective: September 18, 2009

Issued By: Alaska Fiber Star, LLC.

By: 
 Lisa Phillips

Title: Manager, Regulatory Affairs

RCA No. 619	Original	Sheet No. 4.4	
	Canceling	Sheet No.	
Alaska Fiber Star, LLC.			
PART IV – FRAME RELAY SERVICE			
<p>C. <u>Regulations</u> (cont.)</p> <p>7. The PVC must be associated with at least one Frame Relay Port. A Frame Relay Port can be associated with multiple PVCs.</p> <p>8. The PVC can either be a connection between the ports of a Frame Relay Network or between a Frame Relay Network and a DSL Access Service Connection Point.</p> <p>9. A Customer subscribing to a PVC will be referred to as the Controller of the Frame Relay Port. A Customer may request data transmission capability to/from another Customer. Both Customers must subscribe to Frame Relay Service. The Controller of the Frame Relay Port must have written permission from the Controller of the other Frame Relay Port for this data transmission capability.</p> <p>10. The Frame Relay Data Link or Frame Relay Port and PVC may be ordered and billed independently and can have different Customers as Controllers. A request by one Customer in a multipoint Customer service arrangement to discontinue their data link and/or PVC does not result in the disconnection of the Frame Relay Data Link and Port of any of the Customer who may share the transmission of FRS. Each Customer who is responsible for their data link may authorize the disconnect of that Frame Relay Data Link and the Controller may authorize the disconnect of the Frame Relay Port to which the Customer subscribes.</p> <p>11. At service subscription, the Customer must specify the Committed Information Rate (CIR) for each PVC ordered. Any burst beyond the CIR may be labeled Discard Eligible (DE) if the data transfer rate exceeds the CIR of the PVC being used. If the Frame Relay Network develops congestion, the frames marked DE may be discarded. In FRS, the retransmission of discarded frames is administered by the CPE. The cumulative CIR ordered on a single port cannot exceed 200% of the port speed.</p>			
Tariff Advice No. 11-619		Effective: September 18, 2009	

Issued By: Alaska Fiber Star, LLC.

By: 
 Lisa Phillips

Title: Manager, Regulatory Affairs

RCA No. 619	Original Canceling	Sheet No. 4.5 Sheet No.	
Alaska Fiber Star, LLC.			
PART IV – FRAME RELAY SERVICE			
<p>C. <u>Regulations</u> (cont.)</p> <p>12. Error correction is the responsibility of the Customer’s Frame Relay terminal equipment. When the FRS Network is congested, Customer data that exceeds the CIR ordered at service subscription may be discarded. The FRS nodes will discard frames with errors.</p> <p>13. AFS will attempt to achieve a Network Availability Time (NAT) of 99%. NAT is measured as the total number of minutes in a calendar month during which core network PVC routes are available to exchange data between the two network infrastructure node end points, divided by the total number of minutes in a calendar month. For the purposes of this guarantee, a lapse in network availability is calculated commencing with the date on which the Customer informs AFS of the problem and ends on the date of service restoration. For the purposes of this measurement, the PVC route is measured from infrastructure port to infrastructure port, and does not include Customer premise equipment.</p> <p>NAT measurements do not include down times resulting in whole or in part from one or more of the following causes:</p> <ul style="list-style-type: none"> • Any act of omission on the part of the Customer, Customer contractors, or Customer vendors; • Scheduled maintenance; • Labor strikes; or • Natural disasters. <p>NAT is calculated as follows:</p> $\frac{\text{Total minutes of PVC downtime per month}}{=1 - (\text{total number of PVCs}) \times (\text{days in month}) \times (24 \text{ hours}) \times (60 \text{ minutes})}$			
Tariff Advice No. 11-619		Effective: September 18, 2009	

Issued By: Alaska Fiber Star, LLC.

By: 
 Lisa Phillips

Title: Manager, Regulatory Affairs

RCA No. 619	Original Canceling	Sheet No. 4.6 Sheet No.	
Alaska Fiber Star, LLC.			
PART IV – FRAME RELAY SERVICE			
<p>C. <u>Regulations</u> (cont.)</p> <p>13. Network Availability (cont.)</p> <p>In any month in which AFS does not meet its committed Service Level Guarantee, the Customer will receive credit as follows:</p> <ul style="list-style-type: none"> a. In the event that AFS is unable to satisfy the committed NAT for two consecutive months, AFS will provide a credit equal to 5% of the fixed rate for all port and PVC charges for each of the two months. b. In the event that AFS is unable to satisfy the committed NAT for three to four consecutive months, AFS will provide credits for the first two months as specified in a, above, plus a credit equal to 10% of the fixed rate for all port and PVC charges for the third month. c. In the event that AFS is unable to satisfy the committed NAT for five consecutive months, AFS will provide credits for the first four months as specified in b, above, plus a credit equal to 15% of the fixed rate for all port and PVC charges for the fifth month. d. In the event that AFS is unable to satisfy the committed NAT for six consecutive months, AFS will provide credit for the first five months as specified in c, above. In addition, the Customer may (1) discontinue FRS without liability, except for charges incurred prior to the discontinuance, or (2) receive a credit equal to 15% of the fixed rate for all port and PVC charges for the sixth month. Customers opting for (1) must provide written notice to AFS of their intent to discontinue no later than 30 days following the conclusion of the sixth month. 			
Tariff Advice No. 11-619		Effective: September 18, 2009	

Issued By: Alaska Fiber Star, LLC.

By: 
 Lisa Phillips

Title: Manager, Regulatory Affairs

RCA No. 619	Original Canceling	Sheet No. 4.7 Sheet No.	
Alaska Fiber Star, LLC.			
PART IV – FRAME RELAY SERVICE			
<p>D. <u>Rate Regulations</u></p> <ol style="list-style-type: none"> 1. The minimum contract period for Frame Relay Service is one year. 2. A subsequent order to add Frame Relay Data Link(s) or Frame Relay Port(s) to an existing installation will be for a minimum contract period of one year. 3. Service Rearrangements <p style="margin-left: 40px;">Service rearrangements are changes to existing (installed) services which do not result in a change in the physical location of the network interface. (Changes in the physical location of the network interface are treated as moves and are described and charged for as set forth herein.)</p> <ol style="list-style-type: none"> a. Additions to Service <ol style="list-style-type: none"> 1) When service elements are added to an existing service, the added elements must meet any remaining minimum period requirements associated with the service to which they are added. 2) When PVCs are added to an existing FRS, the minimum period for the added PVCs is the remaining term of the port. 3) An addendum to the existing fixed-period service agreement is required when service elements are added to an existing fixed-period service. PVCs may be added to existing fixed-period service on a month-to-month bases without an addendum to the existing fixed-period service agreement. The addendum is for the purpose of identifying service elements that have been added subsequent to establishing the fixed-period agreement. 			
Tariff Advice No. 11-619		Effective: September 18, 2009	

Issued By: Alaska Fiber Star, LLC.

By: 
 Lisa Phillips

Title: Manager, Regulatory Affairs

RCA No. 619	Original	Sheet No. 4.8	
	Canceling	Sheet No.	
Alaska Fiber Star, LLC.			
PART IV – FRAME RELAY SERVICE			
<p>D. <u>Rate Regulations</u></p> <p>3. Service Rearrangements (cont.)</p> <p>a. Additions to Service (cont.)</p> <p>4) Nonrecurring charges will apply for all additions to existing services, service elements, or optional features for which nonrecurring charges normally apply during installation.</p> <p>5) Nonrecurring charge for additional PVCs will be required if PVCs are not purchased with a Frame Relay Port at the time of the original service request.</p> <p>6) Related monthly rates and nonrecurring charges for addition(s) to service are the rates and charges in effect at the time of the addition(s).</p> <p>7) A PVC Rearrangement Charge will be applied whenever a change is made to the CIR of an existing PVC after initial port installation and/or a change is made to the terminating port designation of the PVC.</p>			
Tariff Advice No. 11-619			Effective: September 18, 2009

Issued By: Alaska Fiber Star, LLC.

By: 
 Lisa Phillips

Title: Manager, Regulatory Affairs

RCA No. 619	Original	Sheet No. 4.9	
	Canceling	Sheet No.	
Alaska Fiber Star, LLC.			
PART IV – FRAME RELAY SERVICE			
<p>D. <u>Rate Regulations</u></p> <p>3. Service Rearrangements (cont.)</p> <p>b. Upgrades in Speed or Capacity</p> <p>1) Should the Customer upgrade either a portion or the entire service provided under a fixed-period service agreement to a higher speed or greater capacity, discontinuance charges will not apply, provided all the following conditions are met:</p> <p>a) Both the existing and new services and/or service element(s) are of the same service type (e.g., both Frame Relay Service);</p> <p>b) Both the existing and new services and/or service element(s) are provided solely by the Company;</p> <p>c) The order to discontinue service at an existing speed or capacity and the order for the upgraded service are received by the Company at the same time;</p> <p>d) The new service will be provided at the same customer location as the discontinued service;</p> <p>e) The fixed-period plan for the upgraded service(s) and/or service element(s) meets or exceeds the remaining length of the existing fixed-period plan; and</p> <p>f) The total term of the new agreement is equal to or greater than that total term rate of the existing agreement period.</p>			
Tariff Advice No. 11-619			Effective: September 18, 2009

Issued By: Alaska Fiber Star, LLC.

By: 
 Lisa Phillips

Title: Manager, Regulatory Affairs

RCA No. 619	Original Canceling	Sheet No. 4.10 Sheet No.	
Alaska Fiber Star, LLC.			
PART IV – FRAME RELAY SERVICE			
<p>D. <u>Rate Regulations</u></p> <p> 3. Service Rearrangements (cont.)</p> <p> b. Upgrades in Speed or Capacity (cont.)</p> <p> 2. The term rates for the upgraded services and/or service element will be those rates in effect at the time of the service upgrade. The related nonrecurring charges which apply for the upgrade are the charges in effect at the time of the service upgrade.</p> <p> 3. Should the order to upgrade exclude one or more of the conditions listed above, it will be treated as a discontinuance of the existing service and the establishment of new service. All outstanding minimum period charges and discontinuance charges will apply.</p>			
Tariff Advice No. 11-619		Effective: September 18, 2009	

Issued By: Alaska Fiber Star, LLC.

By: 
 Lisa Phillips

Title: Manager, Regulatory Affairs

RCA No. 619	Original Canceling	Sheet No. 5.1 Sheet No.	
Alaska Fiber Star, LLC.			
PART V – OTHER DATA SERVICES			
<p>A. <u>Virtual LAN Service – High Speed (VLS)</u></p> <p>1. General</p> <p>Virtual LAN Service – High Speed (VLS) is a high speed shared fiber optic transport for the interconnection of Local Area Networks (LANs) and Wide Area Networks (WANs). VLS serves as a LAN extension for Ethernet LANs by providing a virtual private circuit that utilizes public transport. The service is bi-directional, providing high capacity service over private virtual circuits.</p> <p>The electrical signals provided by VLS at the network interface meet IEEE 802.3 requirements. These signals are put onto fiber optic facilities for transport to the network management equipment in a Company central office.</p> <p>VLS is provided over fiber optic facilities, and can be provided on a point-to-point or multi-point basis. Where possible, service will be provided over existing Company facilities. Where suitable facilities are not available, it may be necessary to construct such facilities. Special Construction terms and conditions are applicable if suitable fiber optic facilities do not exist.</p>			
Tariff Advice No. 11-619		Effective: September 18, 2009	

Issued By: Alaska Fiber Star, LLC.

By: 
 Lisa Phillips

Title: Manager, Regulatory Affairs

RCA No. 619	Original	Sheet No. 5.2	
	Canceling	Sheet No.	
Alaska Fiber Star, LLC.			
PART V – OTHER DATA SERVICES			
<p>A. <u>Virtual LAN Service – High Speed (VLS) (cont.)</u></p> <p>2. Service Elements</p> <p>a. Data Link – The Data Link provides the connection from a Customer’s terminal equipment at the network interface to the Company’s network supporting VLS. A Data Link includes a network interface, the network node, and the related fiber optic facility. A monthly rate applies per Data Link per Customer location.</p> <p>b. Connection Bandwidth – In a Customer’s VLS configuration, the Connection Bandwidth is the transmission facility that connects like Data Links between Customer locations. The Connection Bandwidth connects two or more Data Links and is charged on a per month, per Mbps bandwidth basis.</p> <p>3. General Regulations</p> <p>a. VLS is available on a point-to-point or multi-point basis, 24 hours per day, 7 days per week.</p> <p>b. The number of data links in a multi-point arrangement is limited by the technological capabilities of the network.</p> <p>c. VLS utilizes public, shared transport to provide a virtual private circuit arrangement. A non-shared VLS arrangement is not available.</p> <p>d. VLS can only be provided where fiber optic facilities and equipment are available. Refer to General Rules and Regulations section L for Special Construction provisions.</p>			
Tariff Advice No. 11-619		Effective: September 18, 2009	

Issued By: Alaska Fiber Star, LLC.

By: 
 Lisa Phillips

Title: Manager, Regulatory Affairs

RCA No. 619	Original	Sheet No. 5.3	
	Canceling	Sheet No.	
Alaska Fiber Star, LLC.			
PART V – OTHER DATA SERVICES			
<p>A. <u>Virtual LAN Service – High Speed (VLS)</u> (cont.)</p> <p>3. General Regulations (cont.)</p> <p>e. For VLS, equipment space furnished by the Customer under the terms in Obligations of the Customer section will be secured by the Company. This space must be accessible exclusively to the Company, as if the Company were a lesser.</p> <p>f. The actual facility mileage for a VLS circuit, including the distance between the Customer’s premises and the service point for the premises and the distance between service points, if applicable, is dependent on the VLS technology deployed.</p> <p>g. The electrical signals for VLS are in conformance with the requirements specified in IEEE 802.3.</p> <p>4. Rate Regulations</p> <p>a. The initial order for VLS must be for a fixed service period of one, three, or five years. At the end of the initial service period, the Customer may elect the month-to-month option or any of the service periods specified preceding.</p> <p>b. A subsequent order to add any VLS data links to an existing Virtual LAN Service must be for a fixed period of one, three, or five years, or for the remainder of the Customer’s existing fixed period service agreement. The minimum service period for additional VLS elements is 12 months.</p>			
Tariff Advice No. 11-619		Effective: September 18, 2009	

Issued By: Alaska Fiber Star, LLC.

By: 
 Lisa Phillips

Title: Manager, Regulatory Affairs

RCA No. 619	Original Canceling	Sheet No. 5.4 Sheet No.	
Alaska Fiber Star, LLC.			
PART V – OTHER DATA SERVICES			
<p>A. <u>Virtual LAN Service – High Speed (VLS) (cont.)</u></p> <p>4. Rate Regulations (cont.)</p> <p>c. If a fixed period agreement is terminated prior to the end of the period, the Customer is responsible for reimbursing the Company the difference between the rates actually charged and the rates that would have been charged, had the actually period been the original service period. For example, if a Customer agrees to a five-year term and cancels service after three years, the Company will charge the Customer the difference between the five-year rate and the three-year rate for two years.</p> <p>5. Planned Service Interruption</p> <p>Occasionally, routine maintenance will result in an interruption of service. Planned interruptions of service will be scheduled to occur outside of normal business hours and Customers will be notified ten (10) working days in advance of the interruption.</p> <p>The ten (10) working day notice begins upon AFS' notification to the Customer's primary contact, by telephone. This contact will include the date, time, and estimated duration of the service interruption. This telephone contact will represent AFS' compliance with the ten (10) working day notification requirement.</p> <p>AFS will fax or email the Customer confirmation of the scheduled interruption. AFS requests acknowledgement from the Customer that this information has been received, however, AFS will proceed with the scheduled maintenance without the Customer's acknowledgement.</p>			
Tariff Advice No. 11-619		Effective: September 18, 2009	

Issued By: Alaska Fiber Star, LLC.

By: 
 Lisa Phillips

Title: Manager, Regulatory Affairs

RCA No. 619	Original	Sheet No. 6.1	
	Canceling	Sheet No.	
Alaska Fiber Star, LLC.			
PART VI – RATES and CHARGES			
A. <u>Nonrecurring Charges Applicable for Special Services</u>			
			<u>Nonrecurring Charges</u>
	Service Order Charge		\$15.00
	Hourly Engineering Charge		\$90.00
	Hourly Installation Charge		\$75.00
For expedited Engineering and Installation, the hourly rates listed above will be doubled.			
B. <u>High Capacity Service</u>			
Regulations concerning High Capacity Service are set forth in Services section H, preceding.			
		<u>Monthly Rate</u>	<u>Nonrecurring Charges</u>
1.	Channel Termination per Termination - DS1 (1.544 Mbps)	\$75.95	\$370.00
2.	Channel Mileage		
	a. Channel Mileage Facility per Mile - DS1 (1.544 Mbps)	\$63.30	
	b. Channel Mileage Termination per Termination - DS1 (1.544 Mbps)	\$130.15	
Tariff Advice No. 11-619			Effective: September 18, 2009

Issued By: Alaska Fiber Star, LLC.

By: 
Lisa Phillips

Title: Manager, Regulatory Affairs

RCA No. 619	Original	Sheet No. 6.2	
	Canceling	Sheet No.	
Alaska Fiber Star, LLC.			
PART VI – RATES and CHARGES			
B. <u>High Capacity Service</u> (cont.)			
3.	Term Discounts	<u>Percentage</u>	
	-DS1 Service (1.544 Mbps)		
	36 months	10%	
	60 months	20%	
4.	Optional Features and Functions		
		<u>Monthly</u>	<u>Nonrecurring</u>
		<u>Rate</u>	<u>Charges</u>
a.	Automatic Protection		
	Switching, per arrangement*	\$66.90	\$95.00
<p>* An additional Channel Termination charge will apply whenever the spare line is provided as a leg to the Customer Designated Premises.</p>			
Tariff Advice No. 11-619		Effective: September 18, 2009	

Issued By: Alaska Fiber Star, LLC.

By: 
 Lisa Phillips

Title: Manager, Regulatory Affairs

RCA No. 619	Original	Sheet No. 6.3	
	Canceling	Sheet No.	
Alaska Fiber Star, LLC.			
PART VI – RATES and CHARGES			
C.	<u>Frame Relay Service</u>		
		<u>Monthly Rate</u>	<u>Nonrecurring Charge</u>
1.	Data Links, per data link - DS1 (1.544 Mbps)	\$75.95	\$369.90
2.	Port Connection, per Port based on speed - DS1 (1.544 Mbps)	\$418.00	\$22.80
3.	PVC based on CIR speed - DS1 (1.544 Mbps)	\$263.15	\$22.80
4.	PVC Rearrangement Charge		\$22.80
Tariff Advice No. 11-619		Effective: September 18, 2009	

Issued By: Alaska Fiber Star, LLC.

By: 
 Lisa Phillips

Title: Manager, Regulatory Affairs

RCA No. 619	Original	Sheet No. 6.4	
	Canceling	Sheet No.	
Alaska Fiber Star, LLC.			
PART VI – RATES and CHARGES			
D.	<u>Virtual LAN Service – High Speed (VLS)</u>		
		<u>Monthly</u> <u>Rate</u>	<u>Nonrecurring</u> <u>Charge</u>
1.	Ethernet Data Links, at the following rates	\$332.50	\$1,900.00
2.	Connection Bandwidth		
	Month-to-Month and One-Year		
	10 Mbps	\$1,235.00	
	20 Mbps	\$2,470.00	
	30 Mbps	\$3,705.00	
	40 Mbps	\$4,940.00	
	50 Mbps	\$5,557.50	
	60 Mbps	\$6,660.00	
	70 Mbps	\$7,780.50	
	100 Mbps	\$8,645.00	
	Three-Year		
	10 Mbps	\$1,092.50	
	20 Mbps	\$2,185.00	
	30 Mbps	\$3,277.50	
	40 Mbps	\$4,370.00	
	50 Mbps	\$4,916.25	
	60 Mbps	\$5,899.50	
	70 Mbps	\$6,882.75	
	100 Mbps	\$7,647.50	
Tariff Advice No. 11-619		Effective: September 18, 2009	

Issued By: Alaska Fiber Star, LLC.

By: 
Lisa Phillips

Title: Manager, Regulatory Affairs

RCA No. 619

Original

Sheet No. 6.5

Canceling

Sheet No.

Alaska Fiber Star, LLC.

PART VI – RATES and CHARGES

D. Virtual LAN Service – High Speed (VLS) (cont.)

	<u>Monthly Rate</u>	<u>Nonrecurring Charge</u>
2. Connection Bandwidth (cont.)		
Five-year		
10 Mbps	\$ 950.00	
20 Mbps	\$1,900.00	
30 Mbps	\$2,850.00	
40 Mbps	\$3,800.00	
50 Mbps	\$4,275.00	
60 Mbps	\$5,130.00	
70 Mbps	\$5,985.00	
100 Mbps	\$6,650.00	

E. Continuous Property Service

Where the terminals of the lines are on the same continuous property within the same building or continuous property of the Customer. A minimum charge at each Customer designated premises applies.

\$ ICB

\$ ICB

Tariff Advice No. 11-619

Effective: September 18, 2009

Issued By: Alaska Fiber Star, LLC.

By: 
Lisa Phillips

Title: Manager, Regulatory Affairs

RCA No. 619	Original Canceling	Sheet No. 6.6 Sheet No.	
Alaska Fiber Star, LLC.			
PART VI – RATES and CHARGES			
<p>F. <u>Regulatory Cost Charge</u></p> <p>The Regulatory Cost Charge is a special surcharge applied to all regulated retail customer billings to pay the Company's share of the budget of the Regulatory Commission of Alaska.</p> <p style="text-align: center;">Regulatory Cost Charge 2.270% of billing, per month</p>			
Tariff Advice No. 11-619		Effective: September 18, 2009	

Issued By: Alaska Fiber Star, LLC.

By: 
 Lisa Phillips

Title: Manager, Regulatory Affairs